



# Gremo 1050F4

## Service and maintenance manual



**Applies to serial numbers 41101, 51102, 61101–**

Gremo AB  
311 51 Ätran  
Sweden  
Tel. +46 346–60515  
Fax. +46 346–60342  
[www.gremo.com](http://www.gremo.com)  
[info@gremo.se](mailto:info@gremo.se)

Release  
Service and maintenance  
manual in original  
1050F 04EN  
©Gremo 2019



|  |           |  |    |
|--|-----------|--|----|
| <b>1 Service and maintenance .....</b>   | <b>1</b>  | 2.12 Fault report 500 h Copy Customer's Copies.....  | 65 |
| 1.1 Safety rules during service .....  | 1         | 2.13 Report, service during the warranty period after 1,000 hours of operation.....                                  | 66 |
| 1.2 Service and maintenance .....  | 3         | 2.14 Report, service during the warranty period after 1,000 hours of operation (cont'd.).....                        | 68 |
| 1.3 Volume specifications .....  | 4         | 2.15 Fault report 1,000 h.....   | 69 |
| 1.4 Working with oils .....  | 4         | 2.16 Report, service during the warranty period after 1,000 hours of operation Copy Customer's Copies.....           | 70 |
| 1.5 Oil, requirement specification .....   | 5         | 2.17 Report, service during the warranty period after 1,000 hours of operation (cont'd.) Copy Customer's Copies..... | 72 |
| 1.6 Antifreeze, requirement specification .....  | 7         | 2.18 Fault report 1,000 h Copy Customer's Copies .....   | 73 |
| 1.7 Fuel, requirement specification .....  | 8         | 2.19 Report, service during the warranty period after 1,500 hours of operation.....                                  | 74 |
| 1.8 Cleaning of Safety Glass Windows .....   | 9         | 2.20 Report, service during the warranty period after 1,500 hours of operation (cont'd.).....                        | 75 |
| 1.9 Welding Repairs.....   | 10        | 2.21 Fault report 1,500 h.....   | 76 |
| 1.10 Tyres — Air pressure: Manufacturer's recommendations .....  | 12        | 2.22 Report, service during the warranty period after 1,500 hours of operation Copy Customer's Copies.....           | 77 |
| 1.11 Daily maintenance (every 8-10 operating hours) .....  | 16        | 2.23 Report, service during the warranty period after 1,500 hours of operation (cont'd.) Copy Customer's Copies..... | 78 |
| 1.12 Inspection every 50 hours of operation or every week .....  | 19        | 2.24 Fault report 1,500 h Copy Customer's Copies .....   | 79 |
| 1.13 Inspection every 500 hours of operation or every three months .....   | 24        | 2.25 Report, service during the warranty period after 2,000 hours of operation.....                                  | 80 |
| <b>2 Service and maintenance during the warranty period.....</b>   | <b>53</b> | 2.26 Report, service during the warranty period after 2,000 hours of operation (cont'd.).....                        | 81 |
| 2.1 Report, service during the warranty period after 100 hours of operation.....                                   | 54        | 2.27 Fault report 2,000 h.....   | 82 |
| 2.2 Report, service during the warranty period after 100 hours of operation (cont'd.).....                         | 55        | 2.28 Report, service during the warranty period after 2,000 hours of operation Copy Customer's Copies.....           | 83 |
| 2.3 Fault report 100 h.....  | 56        | 2.29 Report, service during the warranty period after 2,000 hours of operation (cont'd.) Copy Customer's Copies..... | 84 |
| 2.4 Report, service during the warranty period after 100 hours of operation Copy Customer's Copies.....            | 57        | 2.30 Fault report 2,000 h Copy Customer's Copies .....   | 85 |
| 2.5 Report, service during the warranty period after 100 hours of operation (cont'd.) Copy Customer's Copies.....  | 58        | 2.31 Report, service during the warranty period after 2,500 hours of operation.....                                  | 86 |
| 2.6 Fault report 100 h Copy Customer's Copies .....  | 59        | 2.32 Report, service during the warranty period after 2,500 hours of operation (cont'd.).....                        | 87 |
| 2.7 Report, service during the warranty period after 500 hours of operation.....                                   | 60        |  |    |
| 2.8 Report, service during the warranty period after 500 hours of operation (cont'd.).....                         | 61        |  |    |
| 2.9 Fault report 500 h.....  | 62        |  |    |
| 2.10 Report, service during the warranty period after 500 hours of operation Copy Customer's Copies.....           | 63        |  |    |
| 2.11 Report, service during the warranty period after 500 hours of operation (cont'd.) Copy Customer's Copies..... | 64        |  |    |

---

|  |    |  |     |
|--|----|--|-----|
| 2.33 Fault report 2,500 h.....   | 88 | 2.44 Report, service during the warranty<br>period after 3,500 hours of operation<br>(cont'd.).....                          | 99  |
| 2.34 Report, service during the<br>warranty period after 2,500 hours of<br>operation Copy Customer's<br>Copy .....           | 89 | 2.45 Fault report 3,500 h.....   | 100 |
| 2.35 Report, service during the<br>warranty period after 2,500 hours of<br>operation (cont'd.) Copy Customer's<br>Copy ..... | 90 | 2.46 Report, service during the<br>warranty period after 3,500 hours of<br>operation Copy Customer's<br>Copy .....           | 101 |
| 2.36 Fault report 2,500 h Copy<br>Customer's Copy .....  | 91 | 2.47 Report, service during the<br>warranty period after 3,500 hours of<br>operation (cont'd.) Copy Customer's<br>Copy ..... | 102 |
| 2.37 Report, service during the<br>warranty period after 3,000 hours of<br>operation.....                                    | 92 | 2.48 Fault report 3,500 h Copy<br>Customer's Copy .....  | 103 |
| 2.38 Report, service during the<br>warranty period after 3,000 hours of<br>operation (cont'd.).....                          | 93 | 2.49 Report, service during the<br>warranty period after 4,000 hours of<br>operation.....                                    | 104 |
| 2.39 Fault report 3,000 h.....   | 94 | 2.50 Report, service during the<br>warranty period after 4,000 hours of<br>operation (cont'd.).....                          | 105 |
| 2.40 Report, service during the<br>warranty period after 3,000 hours of<br>operation Copy Customer's<br>Copy .....           | 95 | 2.51 Fault report 4,000 h.....   | 106 |
| 2.41 Report, service during the<br>warranty period after 3,000 hours of<br>operation (cont'd.) Copy Customer's<br>Copy ..... | 96 | 2.52 Report, service during the<br>warranty period after 4,000 hours of<br>operation Copy Customer's<br>Copy .....           | 107 |
| 2.42 Fault report 3,000 h Copy<br>Customer's Copy .....  | 97 | 2.53 Report, service during the<br>warranty period after 4,000 hours of<br>operation (cont'd.) Copy Customer's<br>Copy ..... | 108 |
| 2.43 Report, service during the<br>warranty period after 3,500 hours of<br>operation.....                                    | 98 | 2.54 Fault report 4,000 h Copy<br>Customer's Copy .....  | 109 |

# 1 Service and maintenance

## 1.1 Safety rules during service

### NOTICE

Read all signs and instructions on the machine and in the safety regulations in the Instruction Manual before you start servicing the machine.

Each of these contains important information about handling and service.

Servicing which is not done correctly can present risks. Make sure that you have enough knowledge, the correct information, the correct tools and the correct equipment in order to be able to carry out the service correctly. Repair or replace broken tools or broken equipment.

You are not allowed to service the machine unless you have the correct knowledge to do the work.

When you handle oil or fuel you should take measures to avoid waste. Oil which is dumped on the ground will cause damage to the environment and may also cause fire. Used oils and fluids should always be taken care of by an authorised company.

If you plan to install a comms radio, mobile phone or similar equipment then the installation must be done professionally in order to eliminate interference with certain electronic components controlling the machine.

### NOTICE

Always switch off the engine during service.



### WARNING

Risk of serious crushing injury or fatal accident!

Always switch off the engine before releasing the cab to tip it up.

Never go under a tipped-up cab unless it is propped up.

Ensure that the cab is propped up if you need to go under it!



### WARNING

During all work on the machine, remember the risk of slipping. You should always use a safety helmet, safety goggles, gloves, safety boots, breathing protection and other necessary protective equipment when required.



### WARNING

The bogie lift can be used as a lifting aid during service and repairs, but always prop up the machine.



### WARNING

When you lift or prop up the machine or parts of the machine, make sure that the equipment you use is intended for this purpose, is appropriately dimensioned, and cannot slip or tip over!



### CAUTION

When you are about to change the engine oil, hydraulic oil or transmission oil: remember that the oil may be hot and can cause burns. Avoid contact with skin and note that oil vapours can cause irritation to airways.



### CAUTION

The exhaust pipes are very hot and can cause serious burns!

### NOTICE

In case of hose breakage: connect the vacuum pump (additional equipment) so that unnecessary oil does not leak out!

## 1.2 Service and maintenance

Preventive maintenance measures are divided into time intervals: daily checks (every 8-10 operating hours), weekly checks every 50 operating hours and checks every 500, 1,000, 2,000 and 5,000 operating hours.

### NOTICE

Regular servicing, and maintenance and servicing during the guarantee period, i.e. the first 2,000 operating hours, are described in the *Service and Maintenance Manual*.

The daily maintenance includes a systematic inspection of all screw joints. This measure is particularly important when the machine is new or has been dismantled. The more accuracy and care you put into the inspection at this stage, the less is the risk of loose screw joints in the future.

### Torque

| Torque table (Nm).<br>Threading | Quality 8.8            | Quality 10.9 | Quality 12.9 |
|---------------------------------|------------------------|--------------|--------------|
| M8                              | 24                     | 33           | 40           |
| M10                             | 47                     | 65           | 79           |
| M12                             | 81                     | 114          | 136          |
| M14                             | 128                    | 181          | 217          |
| M16                             | 197                    | 277          | 333          |
| M18                             | 275                    | 386          | 463          |
| M20                             | 385                    | 541          | 649          |
| M24                             | 665                    | 935          | 1120         |
| M27                             | 961                    | 1350         | 1620         |
| With NordLock                   | Increase torque by 20% |              |              |

## 1.3 Volume specifications

| Part                             | Total volume                               | Replacement volume                     |
|----------------------------------|--|--|
| Engine                           | 11 litres (including filter replacement *) | 10 litres (without filter replacement) |
| Cooling system                   | approx. 20 litres                          | 15 litres                              |
| Hub reductions                   | 2.4 litres x 8                             | 2.4 litres x 8                         |
| Differential                     | 8.0 litres x 2                             | 8.0 litres x 2                         |
| Bogie cases                      | 9.0 litres x 4                             | 9.0 litres x 4                         |
| Gearbox                          | 3.4 litres                                 | 3.4 litres                             |
| Hydraulic system                 | 130 litres                                 | 90 litres                              |
| Fuel tank                        | 120 litres                                 |  |
| Crane base, crane<br>Cranab FC8  | 5.6 litres                                 | 5.6 litres                             |
| Crane base, crane<br>Loglift F59 | 7 litres                                   | 6.5 litres                             |
| Cab tilt pump                    | 0.7 litres                                 | 0.7 litres                             |

\*) incl. the oil in the filter

## 1.4 Working with oils



### CAUTION

All work where you may get into contact with oil involves a risk of skin trouble, e.g. eczema. The risk is greatest in the case of hydraulic oils, but there is also a risk with other types of oil. Careful hygiene is therefore *always* of great importance!

Some hints to remember and observe:

- Avoid contact with oil, especially hot oil!
- If your skin has been exposed to oil, clean it as soon as possible with water and soap, or with a suitable washing cream and water.



- Use protective gloves! Wash your hands before putting the gloves on. A protective cream on your hands will make it easier to clean them later.
- Don't keep any oil-stained rags in your pockets!
- Change oil-stained clothes for fresh ones!
- Always keep an extra overall easily available e.g. in your car or work-shed. Not in the machine where it easily gets dirty.
- Cuts and small wounds must be treated *immediately* by cleaning and applying dressings!
- Avoid breathing oil fumes!
- Wash your hands and arms at every meal break, or as often as possible!

**NOTICE**

Oil drums standing outdoors collect water in the lid, and this water can run down into the oil.

Water-damaged oil results in machine breakdown.

Store oil drums lying horizontally under a roof.

## 1.5 Oil, requirement specification

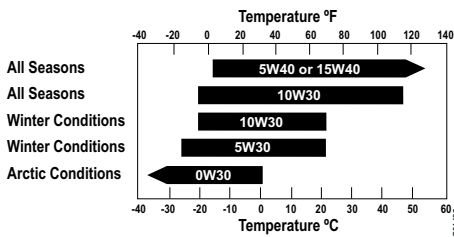

Fig. 1 Lubricating oil viscosity

As the viscosity of lubricating oil is dependent on temperature, the choice of viscosity grade (SAE grade) should be governed by the ambient temperature prevailing at the engine operating site.

The optimum operating conditions are attained if you use the oil viscosity figure shown here as a guide.

Should the temperature fall temporarily below the limits, cold starting may be affected but the engine will not be damaged.

In order to keep wear to a minimum, do not exceed the operating limits for extended periods of time.

Oil changes dictated by the seasonal changes can be avoided by using multi-grade lubricating oils. Multi-grade oils also reduce fuel consumption.

| Part            | Oil/lubricant  |
|-----------------|--|
| Diesel engine   | Engines should be lubricated with MOTOREX engine oil or equivalent which meets the manufacturer's specifications, see <i>sub-supplier's documentation</i> for diesel engine. |
| Hub reductions, | MOTOREX LS UNIVERSAL SAE 90 GL5 or similar.  |

| Part                               | Oil/lubricant   |
|------------------------------------|---|
| Differential cases,<br>Bogie cases |   |
| Gearbox                            |   |
| Crane base                         |   |
| Hydraulic system                   | MOTOREX COREX HV 46   |
| Cab tilt pump                      | TEXACO Rando Ashless 8401   |
| Articulated joint                  | For maximum bearing life, use LGHB204 grease for all articulated joints.  |
| Grease, normal                     | TEXACO Universal Grease Type EP or similar. Use a grease containing lithium or silicone. Type: NLGI class 2. <b>Not</b> with molybdenum disulphide! |

## 1.6 Antifreeze, requirement specification

Approved antifreeze is propylene glycol.

### NOTICE

Do not mix ethylene glycol and propylene glycol. If you have the slightest doubt, pour out, clean and refill with a new mixture.

## 1.7 Fuel, requirement specification

Engines should be run on commercial diesel fuel which meets the manufacturer's specifications, see *sub-supplier's documentation* for diesel engine.

### NOTICE

It is important to only use fuel that meets the standards specified.

Fuel with a higher sulphur content will damage the engine and the after-treatment system.

Only low-sulphur fuel should be used.

## 1.8 Cleaning of Safety Glass Windows

### 1.8.1 Cleaning

Wash the window with lukewarm water and a mild neutral detergent. Use washing-up detergent or a similar soap-based detergent. Rinse carefully with clean water, then wipe dry with a soft, clean cloth.

### 1.8.2 Removing stains

Remove stains of resin, paint, grease, etc. before the stain dries. Use a soft cloth with one of the approved solvents listed below. After the stain has been removed, clean according to the above instructions.

| Approved solvents for cleaning of Safety Glass Windows |
|--|
| Pure Isopropyl Alcohol (IPA)                           |
| Ethanol  |
| Hexane   |
| Butanol  |
| White Spirit   |
| Heptane  |
| Light petrol   |
| Butyl-Ethyl Glycol                                     |



#### CAUTION

Solvents can cause skin problems and eczema. Solvents can be poisonous. Breathing solvent fumes can be dangerous. Solvents can be inflammable. Follow the instructions from the solvent manufacturer.

## 1.9 Welding Repairs

### NOTICE

Prior to beginning any welding, read this chapter carefully!

### 1.9.1 Prior to welding, the following measures must be taken

- Turn off the main power switch.
- (Disconnect the earth cable between the battery and the frame).
- (Disconnect the generator's plus cables).
- Disconnect the fire extinguishing system's central unit by removing main fuse F57.
- Fit the safety screw in the fire extinguisher tank.
- Connect the ground terminal of the welding equipment as close as possible to the welding location.
- Disconnect all computer cables when welding is taking place near the cab, engine control, climate system, DASA, GreControl, radio, etc.

After any welding, ensure that you reset all the necessary items correctly before restarting the machine.



### CAUTION

Heated paint emits poisonous fumes which are dangerous to inhale. Always remove all paint from the welding location!

### NOTICE

Never carry out any welding repairs on frames, articulated joint or crane without first contacting an authorised service dealer or the service department at Greimo AB.

### NOTICE

Always bear in mind the danger of fire. Always keep a hand-held fire extinguisher within reach!

**NOTICE**

Remember that welding close to the fire extinguishing system's detector coil may cause it to burn off and release the contents of the fire extinguisher tank! In order to ensure that the fire extinguisher tank is not accidentally deployed, fit the safety screw. See *Other equipment and optional equipment; Fire extinguishing system in the Instruction Manual*.

**1.9.2 General**

The machine is fabricated from high-tensile steel in the frames and the articulated mid-joint. The standard beams and grille are made of special steel. Welding repairs can be carried out on them using the following electrodes:

Welding electrodes, recommendations

|                                     |
|-------------------------------------|
| <b>Type of electrode: pin</b>       |
| Elga P 62MR                         |
| OK 48.08 (ESAB)                     |
| OK 48.00 (ESAB)                     |
| <b>Type of electrode: tube bar</b>  |
| Elga Core MXA100XP                  |
| ESAB OK Tubrod 14.10                |
| <b>Type of electrode: solid bar</b> |
| ESAB OK Autrod 12.51                |

## 1.10 Tyres — Air pressure: Manufacturer's recommendations

### **DANGER**

Never stand in front of a tyre while it is being inflated! Do not exceed the prescribed tyre pressure, which should be checked at ambient temperature. If there is a change to a different version of tyre or wheel rim, a different tyre pressure may apply — contact Gremo.

Danger!

To avoid serious accidents, always follow directions for inflating tyres.

### **WARNING**

Before a wheel is replaced, the tyre must first be emptied of air.

Risk of tyre explosion! Danger!

Empty the tyre by removing and dismantling the valve.

### **WARNING**

If the wheel rim is damaged, handling the wheel is extremely dangerous!

Risk of tyre explosion! Danger!

Have wheels replaced by a service department authorised to handle tyres!

### **WARNING**

Antifreeze can be explosive When tyres are inflated, the air must therefore not contain any antifreeze.

**Table 1 Nokian Recommended air pressure**

|                               | Front/Tractor                    | Front/Tractor | Rear/Carriage                    | Rear/Carriage |
|-------------------------------|----------------------------------|---------------|----------------------------------|---------------|
| Nokian                        | With or without anti-skid device | With tracks   | With or without anti-skid device | With tracks   |
| 600/50-22.5 TRS<br>LS-2 SF/16 | 350 kPa                          | 430 kPa       | 430 kPa                          | 430 kPa       |



**Table 1 Nokian Recommended air pressure (cont.)**

|                                       | Front/Tractor | Front/Tractor | Rear/Carriage | Rear/Carriage |
|---------------------------------------|---------------|---------------|---------------|---------------|
| 710/40-22.5/<br>Forest King SB-<br>16 | 310 kPa       | 430 kPa       | 390 kPa       | 430 kPa       |
| 710/40-22.5/LS-<br>2 SF/16            | 310 kPa       | 430 kPa       | 390 kPa       | 430 kPa       |

**Table 2 Trelleborg Recommended air pressure**

|                        | Front/Tractor                       | Front/Tractor | Rear/Carriage                       | Rear/Carriage |
|------------------------|-------------------------------------|---------------|-------------------------------------|---------------|
| Trelleborg             | With or without<br>anti-skid device | With tracks   | With or without<br>anti-skid device | With tracks   |
| 600/50-22.5 LS 2<br>16 | 350 kPa                             | 500 kPa       | 450 kPa                             | 500 kPa       |
| 650-12-T422 ET-<br>20  | 350 kPa                             | 500 kPa       | 450 kPa                             | 500 kPa       |
| 710/40-22.5 LS 2<br>16 | 300 kPa                             | 500 kPa       | 400 kPa                             | 500 kPa       |

**Table 3 Tianli Recommended air pressure**

|                         | Front/Tractor                       | Front/Tractor | Rear/Carriage                       | Rear/Carriage |
|-------------------------|-------------------------------------|---------------|-------------------------------------|---------------|
| Tianli                  | With or without<br>anti-skid device | With tracks   | With or without<br>anti-skid device | With tracks   |
| 600/50-22.5 HF-<br>2 16 | 350 kPa                             | 500 kPa       | 400 kPa                             | 500 kPa       |
| 700/45-22.5 HF-<br>2 16 | 350 kPa                             | 500 kPa       | 450 kPa                             | 500 kPa       |

100 kPa = 1 bar

All tyres are from the factory (Gremo) and inflated to 450 kPa.

The minimum pressure is approximately 50 kPa below the stated values and the maximum pressure is around 50 kPa above the stated values.

- Use min. pressure if the ground is easy to drive on and relatively free from stones

- Use max. pressure on difficult and stony ground.

### NOTICE

You should check tyre pressure regularly. Remember to check tyre pressure at low temperatures, the pressure is then lower than in hot summer weather.

### NOTICE

The machine must not be loaded when the tyre pressure is checked.

#### Low tyre pressure, advantages:

- Good comfort.
- Large contact surface.
- Lower ground pressure
- Increased traction
- Reduced formation of wheel tracks.

#### Low tyre pressure, disadvantages:

- Reduced stability.
- Increased risk of hose damage/wear.

#### High tyre pressure, advantages:

- Gives better protection against tyre side damage.
- Increased stability.
- Requirement for track use.

#### High tyre pressure, disadvantages:

- Reduced comfort.
- Increased risk of cutting and puncture damage.
- Increased sensitivity to spot loads.
- Increased formation of wheel tracks
- Poorer grip.

## 1.10.1 Filling of fluid in forestry tyres



Fig. 2 Level, filling tyres with fluid

The tyres can be filled with fluid to increase the machine's stability and traction

Gremo recommends filling 50% of the tyres' volume. Maximum permitted is 75%.

The fluid should consist of water. At temperatures below zero, the fluid used should be a mixture of calcium chloride/water or glycol/water

By turning the wheel and pressing in the valve needle, it is easily possible to determine whether the tyre is filled to 75% or 50% fluid.

Calcium chloride increases the fluid's density by up to 1.2 kg/litre in a 35% blend.

Fluid-filled tyres are less elastic owing to their smaller air volume and are therefore more vulnerable to spot loads. Rolling resistance and the dynamic forces acting on the wheel rims and suspension components are also higher.

### NOTICE

When changing tyres, use the right kind of tyre paste intended for heavy vehicles or forestry machinery. Otherwise, the tyre may slip on the rim.

## 1.11 Daily maintenance (every 8-10 operating hours)

### 1.11.1 Lubrication

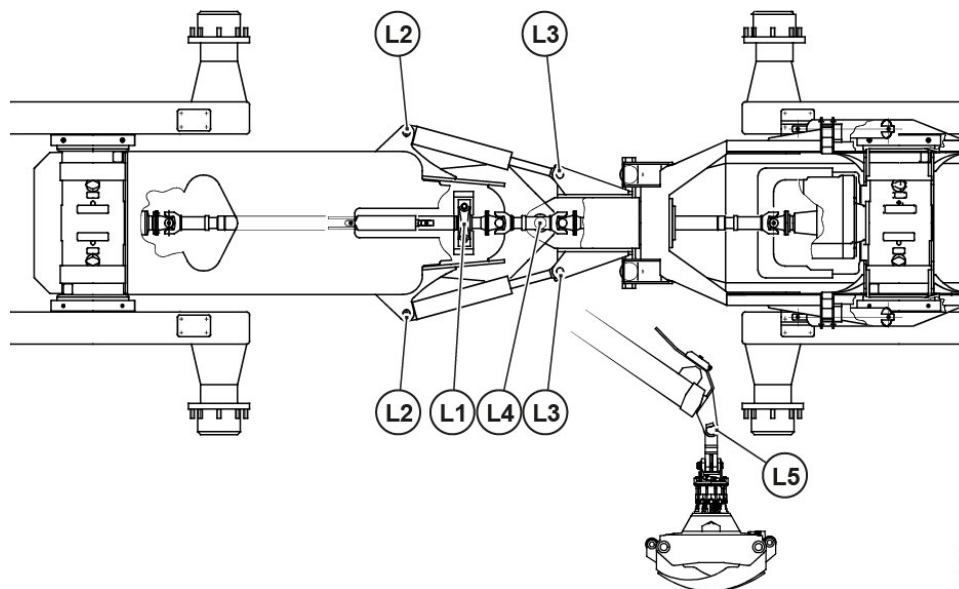
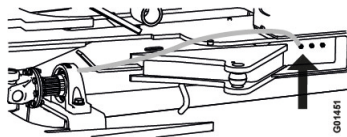
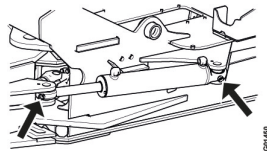
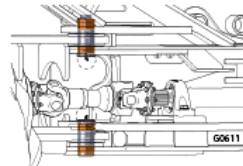

Fig. 3 L = Lubricate= Lubricate

| Pos.   | Lubrication point                | Nipples               | Comments/reference  |
|--------|----------------------------------|-----------------------|---|
| L1     | Support bearing, propeller shaft | 1                     | Drawn out to the left-hand lubrication point at the side.<br>                                       |
| L2, L3 | Steering cylinder                | 1+1 right<br>1+1 left |   |
| L4     | Articulated steering joint       | 1+1                   | To be lubricated with <b>LGHB204</b> , an SKF grease for bearing joints subject to heavy loads.<br> |
| L5     | Rotator link                     | 1+1                   | See <i>sub-supplier documentation</i> for rotator.  |

## 1.11.2 Check

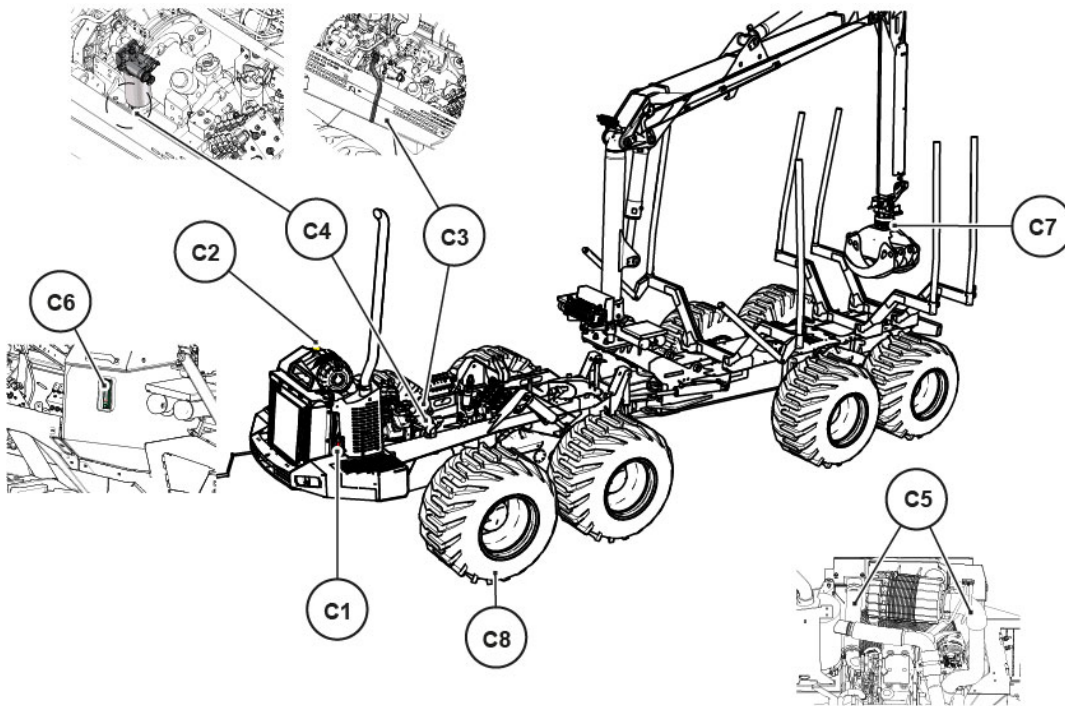

Fig. 4 C = Check

|    | Component  | Reference  |
|----|--|--|
| C1 | Diesel engine: lubricating oil level with dipstick.  |  |
| C2 | Coolant level in radiator.   |  |
| C3 | Diesel engine's crankcase ventilation.   | Check that it is free from dirt and ice, free exit of air!   |
| C4 | Drain the fuel prefilter when indicated in GreControl.                                     |  |
| C5 | Check the diesel engine's air intake hoses.  |  |
| C6 | Hydraulic oil level: via the steering system or via the sight glass in the hydraulic tank. | See <i>Driving instructions, checks before starting, hydraulic system</i> in the instruction manual. |
| C7 | Grapple claw, rotator, vibration damper, etc.  | See <i>sub-supplier documentation</i> for each component.  |

|    | Component   | Reference   |
|----|---|---|
| C8 | Tyres, general condition, visual check  | See 1.10 Tyres — Air pressure: <i>Manufacturer's recommendations</i> , page 12.                                 |
| C  | The machine's various fluid sub-systems with regard to leakage.   | See <i>Driving instructions, checks before starting, Engine and Hydraulic system</i> in the instruction manual. |
| C  | Fire extinguishing system:<br>– that the "ERROR" lamp is off.<br>– that the "OPERATION" lamp is on.<br>– that the "NOT AUTO" lamp only comes on when the machine's ignition is on and the parking brake is not engaged (normal driving).<br>– keep the mode selector in the "TEST" setting to check the audible and visible alarms. | See <i>Fire extinguishing</i> in the instruction manual under <i>Other and additional equipment</i> .           |

### 1.11.3 Cleaning

Clean the machine of snow, twigs, soil etc. Also clean the tracks of ice, snow, twigs, etc.

# 1.12 Inspection every 50 hours of operation or every week

## 1.12.1 Lubrication

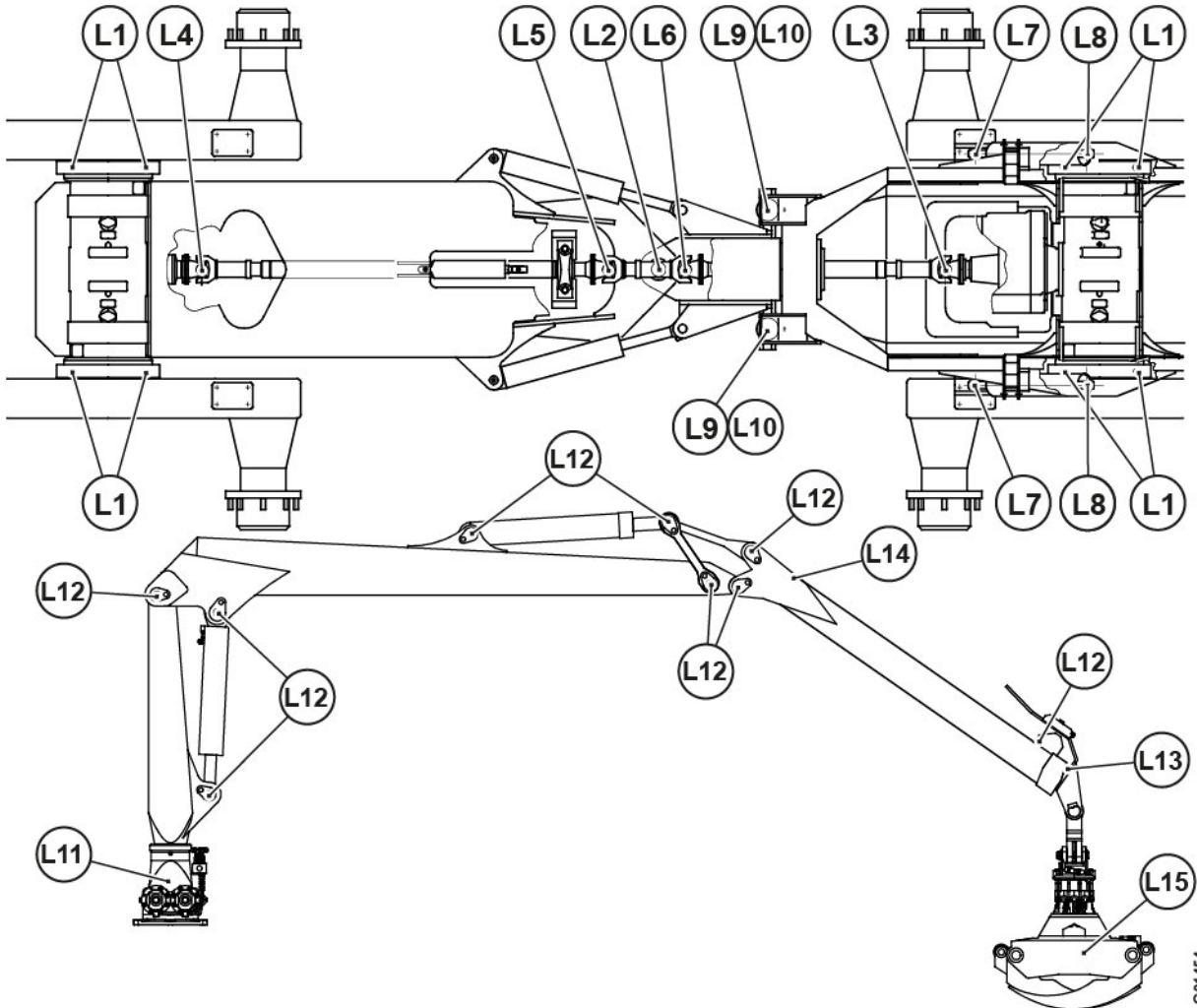
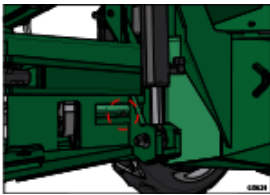
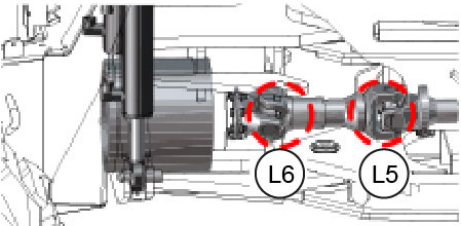

Fig. 5 L = Lubricate

| Pos. | Lubrication point   | Nipples | Comments/reference  |
|------|---|---------|---|
| L1   | Bogie, bearings front and back.<br><br>5 lubrication points in each bearing, located as shown. 2 in the upper corner and 3 in the lower corner. | 5+5     |   |
| L2   | Articulated joint   | 1+1     | Insert a screwdriver or similar under the sealing ring on the opposite side to aerate and to ensure that the grease has penetrated. |

| Pos. | Lubrication point   | Nipples | Comments/reference   |
|------|---|---------|--|
|      |   |         |    |
| L3   | Universal joint (front)   | 1       |  |
| L4   | Universal joint (rear)  | 1       |  |
| L5   | Universal joint (rear),<br>intermediate axle  | 1       | <br>G01463   |
| L6   | Universal joint (front),<br>intermediate axle   | 1       |  |
| L7   | Bogie cylinder, Piston rod<br>ear   | 1+1     |  |
| L8   | Bogie cylinder, cylinder<br>housing ear   | 1+1     |  |
| L9   | Articulated joint stabilising<br>cylinder, piston rod ear   | 1       |  |
| L10  | Articulated joint stabilising<br>cylinder housing ear   | 1       |  |
| L11  | Crane base, Lubrication<br>points in upper bushing. Oil<br>level in crane base, filled<br>with API GL5 (GearTex EP-C<br>80W-90) | 2       | See also <i>sub-supplier documentation</i> for<br>each crane.  |
| L12  | Crane joints  | 12      | See also <i>sub-supplier documentation</i> for<br>each crane.  |
| L13  | Boom extension/(Wear<br>plates)   |         | Lubricate with teflon spray, make sure that<br>oil gets into the spaces between surfaces<br>with significant loads.<br><br>See also <i>sub-supplier documentation</i> for<br>each crane. |
| L14  | Double boom extension<br>chains   |         | Lubricate the chains with chain lubricant or<br>equivalent by brushing.  |



| Pos. | Lubrication point  | Nipples      | Comments/reference   |
|------|--|--------------|--|
|      |  |              | See also <i>sub-supplier documentation</i> for each crane.                                       |
| L15  | Grapple Cranab CR280<br>Grapple Hultdins SPG260<br>Grapple Hassela 028 | 8<br>8<br>10 | See also <i>sub-supplier documentation</i> for each grapple.                                     |
| L    | Claw coupling, winch   |              | If the winch is not in continuous use, the lubrication interval is 2,000 hours or once per year. |

### 1.12.2 Check

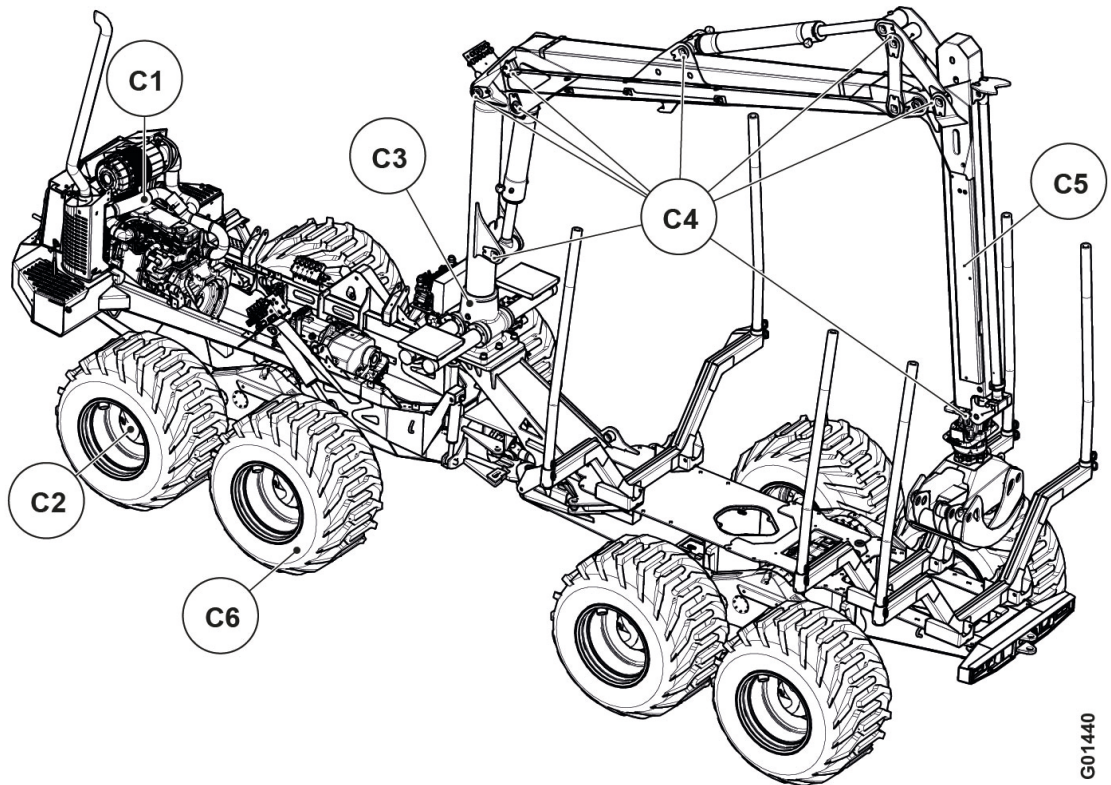

G01440

Fig. 6 C = Check

| Pos. | Component  | Reference/Measure   |
|------|--|---|
| C1   | Drive belt, (wear etc.)  |   |
| C2   | Wheel bolts  | Torque for M22 <b>920 Nm</b>  |
| C3   | Oil level in the crane base  | See also <i>sub-supplier documentation</i> for each crane.  |
| C4   | Crane axles and interlocks   | See also <i>sub-supplier documentation</i> for each crane.  |
| C5   | Telescopic extension chains  | See also <i>sub-supplier documentation</i> for each crane.  |
| C6   | Tyre pressure  | See 1.10 Tyres — Air pressure: <i>Manufacturer's recommendations</i> , page 12.                       |
| C    | Hydraulic hoses  | Check for leakage. Pull out the hose connections and replace worn hoses                               |
| C    | Fire extinguishing system:<br>- - that pressure in the extinguisher tank is at least 90 bar (green area) | See <i>Fire extinguishing</i> in the instruction manual under <i>Other and additional equipment</i> . |

| Pos.            | Component  | Reference/Measure                   |
|-----------------|--|-------------------------------------|
|                 | - and that detector pressure is at least 15 bar (green area).  |                                     |
| C               | Oil level in the winch gearbox, in continual use.  | See 1.13.15 <i>Winch</i> , page 52. |
| <b>Test-run</b> |  |                                     |
| C               | Test run the diesel heater for a few minutes to check that the heater starts and doesn't turn off immediately! |                                     |

## 1.13 Inspection every 500 hours of operation or every three months

### 1.13.1 Lubrication

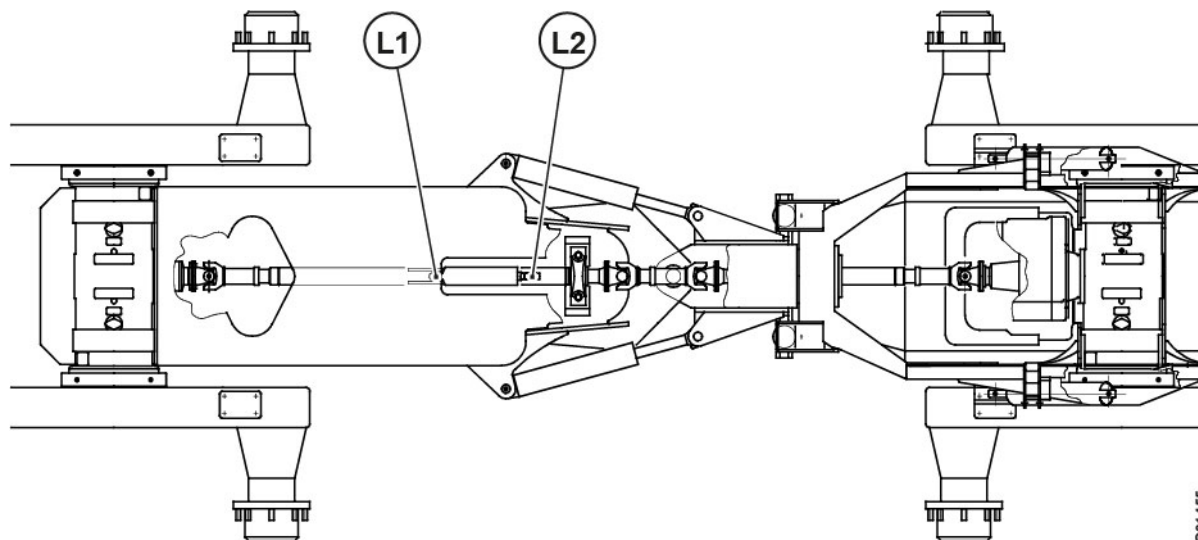



Fig. 7 L = Lubricate

| Pos. | Lubrication point                     | Nipples | Comments/reference  |
|------|---------------------------------------|---------|---|
| L1   | Gate cylinder rear articulated joint  | 1       | Drawn out to the middle and right-hand lubrication points at the side.  |
| L2   | Gate cylinder front articulated joint | 1       |   |
| L    | All lubrication points                |         | As for daily and weekly maintenance – see 1.11 <i>Daily maintenance (every 8-10 operating hours)</i> , page 16 and 1.12 <i>Inspection every 50 hours of operation or every week</i> , page 19 |

### 1.13.2 Change Oil — Filters

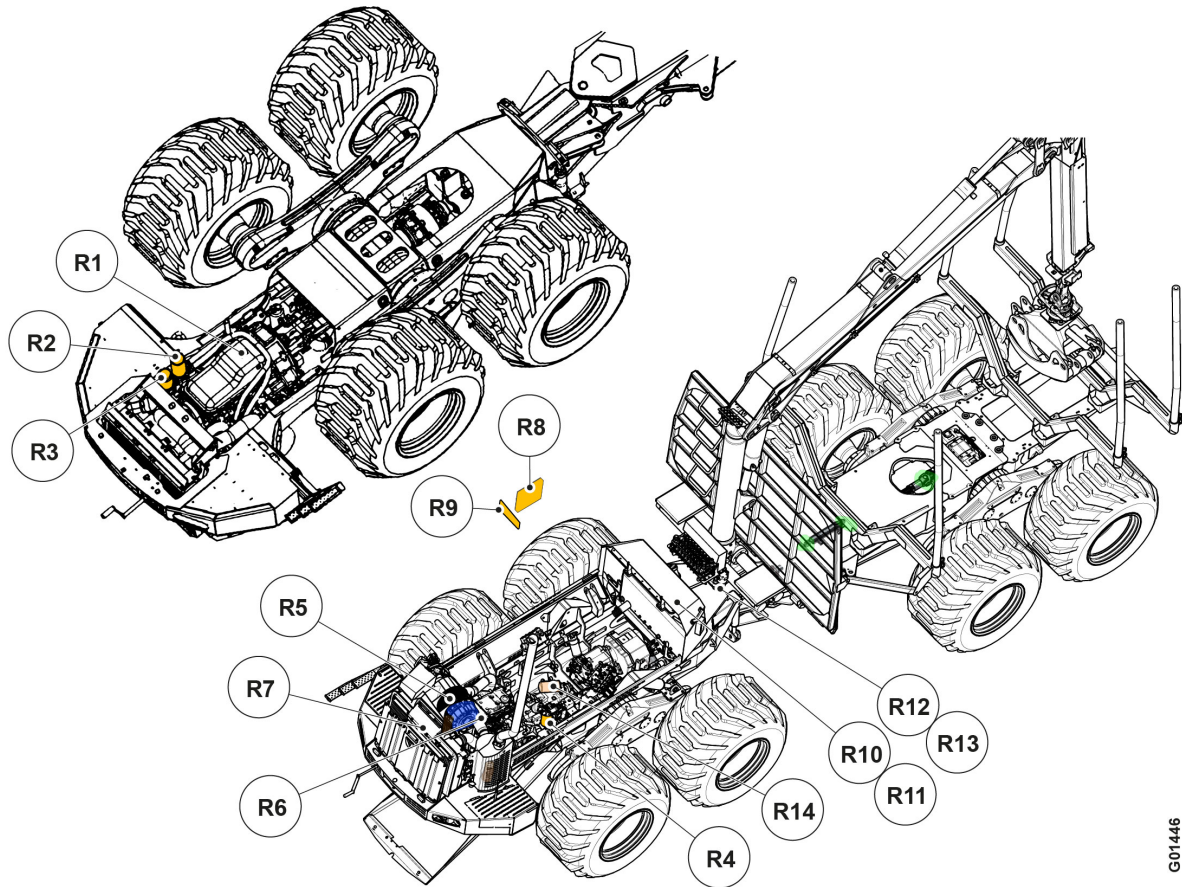

Fig. 8 R = Replace

| Pos.          | System                | Part   | Action                                   | Reference  |
|---------------|-----------------------|--|--|--|
| <b>Engine</b> |                       |  |  |  |
| R1            | Lubrication system    | Engine oil   | 11 litres (including filter replacement) | See 1.13.4 <i>Replacing oil</i> , page 30.                           |
| R2            |                       | Oil filter   |  | See 1.13.5 <i>Replacing oil filters</i> , page 31.                   |
| R3            | Fuel system           | Fuel filter  |  | See 1.13.6 <i>Replacing fuel filters</i> , page 32.                  |
| R4            |                       | Fuel prefilter   |  | See 1.13.7 <i>Replacing fuel prefilters</i> , page 33.               |
| R5            | Air filtration system | The air filter is replaced when the alarm in GreControl is activated. The safety filter is replaced if necessary, i.e. if the safety filter is |  | See <i>Replacing filter cartridges and safety filters</i> , page 38. |

| Pos.                    | System                  | Part   | Action  | Reference  |
|-------------------------|-------------------------|--|---|--|
|                         |                         | clogged with dirt or every alternate air filter replacement.                         |   |  |
| R6                      | Crankcase ventilation   | <b>Every 2,000th hour of operation.</b><br>Replacement of crankcase filters          |   | See <i>sub-supplier documentation</i> for diesel engine.           |
| R7                      | Cooling system          | <b>Every 2,000th hour of operation.</b><br>Clean cooling system and replace coolant. |   | See 1.13.9 <i>Cooling system</i> , page 34.                        |
| <b>Cab</b>              |                         |  |   |  |
| R8                      | Air conditioning system | Fresh air filter   | Replace-<br>ment  | See 1.13.10 <i>Air conditioning system</i> , page 37.              |
| R9                      |                         | Recirculation filter   |   |  |
| <b>Hydraulic system</b> |                         |  |   |  |
| R10                     | Hydraulic oil tank      | Return filter  | Replace-<br>ment<br><br><b>Every 1,000th hour of operation.</b> | See <i>Replacement of return filters</i> , page 42.                |
| R11                     | Hydraulic oil tank      | Breather filter  | Replace-<br>ment<br><br><b>Every 1,000th hour of operation.</b> | See <i>Replacement of breather filters</i> , page 43.              |
| R12                     | Hydraulic oil           | Off-line filter  | Replace-<br>ment<br><br><b>Every 1,000th hour of operation.</b> | See <i>Replacement of off-line filter hydraulic oil</i> , page 43. |

| Pos. | System               | Part         | Action   | Reference   |
|------|----------------------|--------------|--|---|
| R13  | Crane control levers | Pilot filter | Replacement<br><br><b>Every 1,000th hour of operation.</b> | See <i>Replacing pilot filter crane control</i> , page 44.        |
| R14  | Transmission pump    | Filter       | Replacement<br><br><b>Every 1,000th hour of operation.</b> | See <i>Replacement of filter for transmission pump</i> , page 44. |

### 1.13.3 Check/adjust/replace

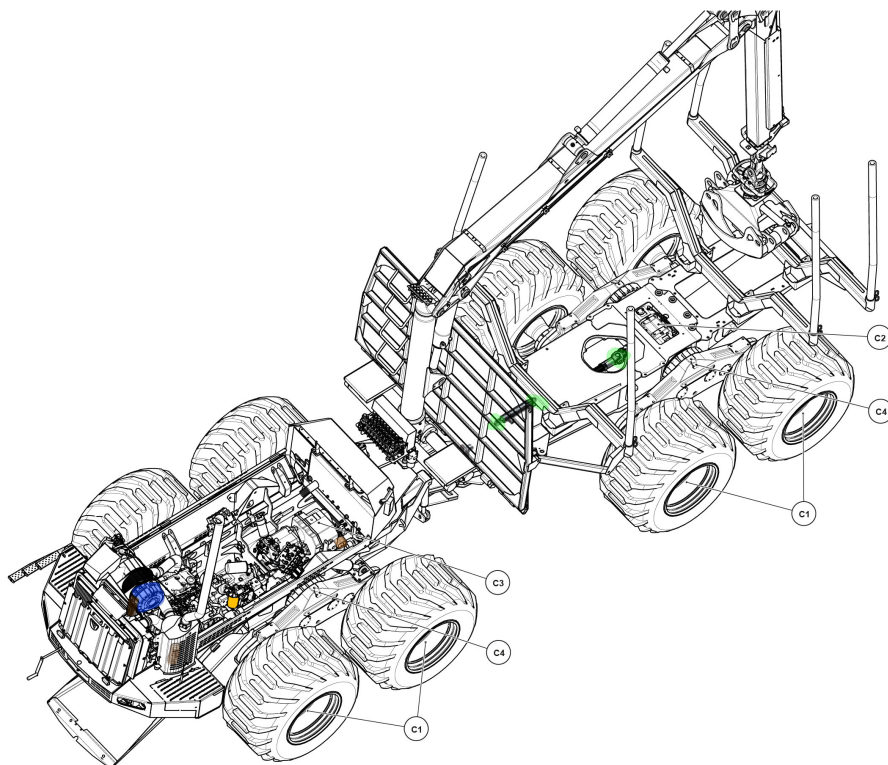

Fig. 9 C = Check

| Pos. | System                        | Action  | Reference  |
|------|-------------------------------|---|--|
| C1   | Hub reductions                | Checking oil level  | See <i>Hub reduction</i> , page 51.  |
| C2   | Differentials                 | Checking oil level  | See <i>The differential</i> , page 51.   |
| C3   | Gearbox                       | Checking oil level  | See <i>Transmission oil, change and level check</i> , page 46.                   |
| C4   | Bogie cases                   | Checking oil level  | See <i>Oil level check in bogie axles</i> , page 51.                             |
| C    | Winch gearbox                 | Checking oil level  | See 1.13.15 <i>Winch</i> , page 52.  |
| C    | Parking brake                 | Check function  | See <i>Safety regulations, Checking parking brake</i> in the Instruction Manual. |
| C/R  | Drive belt and belt tensioner | Check/Replacement<br><b>Every 1,000th hour of operation.</b><br><br>Check the condition of the drive belt and the function of the belt tensioner. | See <i>Sub-supplier documentation</i> for diesel engine.                         |



| Pos. | System           | Action  | Reference   |
|------|------------------|---|---|
| C/R  | Hydraulic oil    | <p>Check condition of hydraulic oil/Replace hydraulic oil</p> <p><b>Every 1,000th hour of operation.</b></p> <p>If analysis result of hydraulic oil is approved, hydraulic oil replacement may be postponed by 1,000 operating hours.</p> | <p>see <i>Sampling and analysis of condition of hydraulic oil</i>, page 41</p> <p>and <i>Changing hydraulic oil</i>, page 42.</p> |
| C/R  | Vibration damper | <p>Check</p> <p><b>Every 2,000th hour of operation</b></p> <p>Check crank axle vibration damper</p>   | <p>See <i>Sub-supplier documentation</i> for diesel engine.</p>   |
| C    | Valve clearance  | <p>Check/Adjustment</p> <p><b>Every 5,000th hour of operation or as indicated in GreControl.</b></p>  | <p>See <i>sub-supplier documentation</i> for diesel engine.</p>   |

## 1.13.4 Replacing oil



Fig. 10 Removal of oil drain plug

1. Warm the engine until the coolant temperature is 60°C.
2. Park the machine on a level surface.
3. Stop the engine.
4. Place a container under the engine's oil drain plug.
5. Unscrew the oil drain plug.
6. Drain off the oil.

### NOTICE

Collect the oil in a container, don't let it run off into the ground! Comply with prevailing regulations for proper disposal.



### CAUTION

Be careful when draining hot oil. Risk of burns.

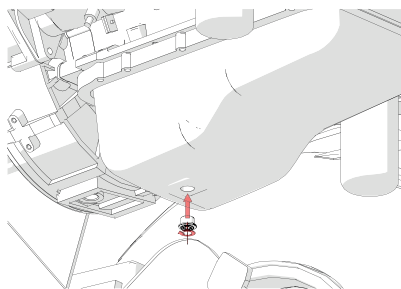

Fig. 11 Refitting oil drain plug

7. Screw the drain plug back in place with a new gasket and tighten to 80 Nm.

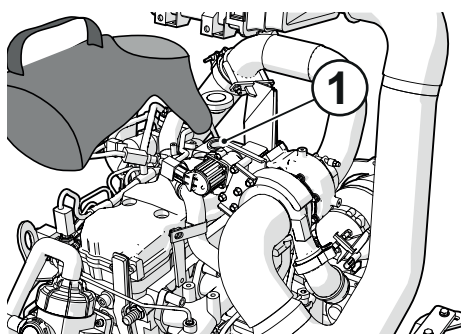

Fig. 12 Filling oil

8. Fill up with oil; for correct oil volume, see 1.3 *Volume specifications*, page 4.

9. Check the oil level.

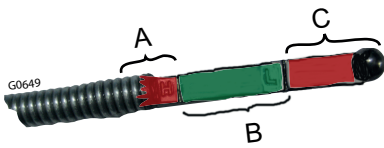

Fig. 13 Oil dipstick

- a. Oil level too high
- b. Correct engine oil level
- c. Oil level too low

10. Start the engine, let it run at idling speed and check the oil plug and oil filter for any leaks.

### NOTICE

The engine must build up oil pressure within 15 seconds after being started. If oil pressure is not built up within 15 seconds after being started, immediately switch off the engine to prevent damage. Ensure that the engine has the correct oil level.

Switch off the engine, wait at least 15 minutes and check the oil level once again.

## 1.13.5 Replacing oil filters



Fig. 14 Removal of old oil filter

1. Clean the area around the filter head.
2. Loosen the oil filter (C) using a filter tool and remove the filter.
3. Collect any dripping oil.
4. Clean the gasket surface of the filter head.

### NOTICE

The O-ring can stick to the filter head.  
Remove the O-ring before fitting a new filter.

5. Fill the new filter with clean oil.

### NOTICE

If the new filter is not pre-filled with oil when the engine is started, the engine will lack lubrication when the filter is pumped full of oil.

*This can damage the engine!*

To avoid this, the new filter must be manually pre-filled before it is fitted.

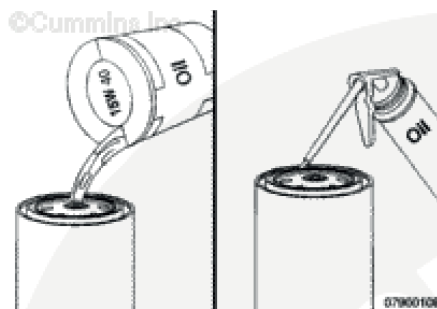

Fig. 15 Fitting new oil filter

6. Lightly lubricate the O-ring and sealing surface of the new oil filter with clean oil.
7. Screw in the filter by hand until the O-ring comes into contact with the filter head.
8. Tighten the fuel filter an additional 3/4 to one turn.
9. Check the oil level.
10. Check the oil pressure.
11. Check that the oil filter is not leaking.

 **CAUTION**

Hot oil!  
Risk of burns!

### 1.13.6 Replacing fuel filters



Fig. 16 Removing fuel filters

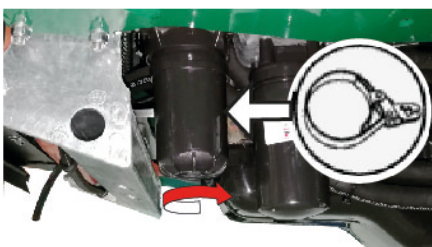

Fig. 17 Fitting a new fuel filter

Remove the fuel filter using a filter wrench and unscrew the filter.

Collect any residual fuel and sort the filter as hazardous waste or pass it on to the company that handles your hazardous waste.

Get the new filter and remove its protective cover.

Apply a thin layer of oil or fuel to lubricate the gasket. Use the tip of your finger to spread it out.

Screw the new fuel filter into place until the gasket touches the filter head.

Tighten the filter using the removal tool by turning it a 3/4 turn or using 34 Nm of torque.

Check for leaks.

Pump using the pump on the prefilter until you hear the fuel return to the tank. See also 1.13.8 *Air bleeding the fuel system*, page 33.

**NOTICE**

Do not fill the fuel filter with fuel in advance! Dirt can get into the fuel system and cause damage.

 **CAUTION**

Keep naked flames away when working on the fuel system! Smoking prohibited! Risk of fire!

## 1.13.7 Replacing fuel prefilters

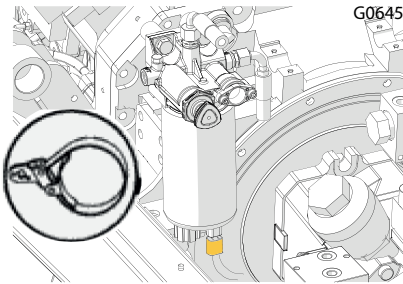

Fig. 18 Replacing fuel prefilters

1. Stop the engine.
2. Put a container under the filter to collect the fuel.
3. Remove the wiring for the water-content sensor.
4. Loosen the fuel prefilter using a suitable tool.
5. Clean the gasket surface of the filter head.
6. Lightly lubricate the rubber seal of the new fuel prefilter.
7. Screw the new filter into place until the gasket touches the filter head.
8. Tighten the fuel filter an additional 3/4 of a turn to reach a torque of 34 Nm.
9. Refit the wiring for the water-content sensor.

When the engine is started again after maintenance work or if the tank is run empty it is essential to vent the fuel system.

## 1.13.8 Air bleeding the fuel system

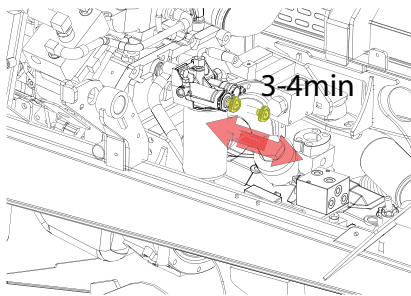

Fig. 19 Pump handle on the fuel prefilter

The fuel system is bled using the pump handle on the fuel pre-filter, which is mounted behind the frame on the left side of the engine carriage under the cab.

Vent the fuel system as follows:

1. Tip up the cab to access the pump handle.
2. Unscrew the pump handle.
3. Use the pump handle to pump for approx. 3 minutes or until you can hear fuel streaming back to the fuel tank, this is indicated by the fuel tank making a weak noise.
4. Try to start the engine.

If the engine doesn't start, repeat step 3 again. If the engine doesn't start at the second attempt, contact your service dealer.

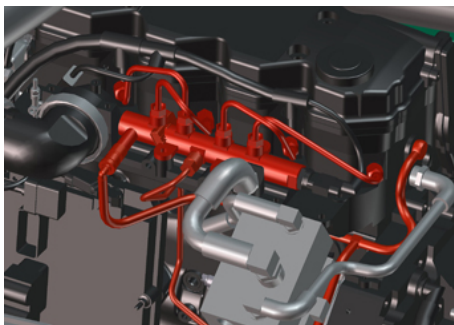

Fig. 20 High pressure section of the fuel system

### CAUTION

The high pressure fuel lines from the fuel pump and the fuel distributor on the engine contain fuel at very high pressure. Never loosen the pipe couplings or similar in the high pressure section of the fuel system, or when carrying out a service or bleeding the system. Risk of injury or damage to the machine!

### NOTICE

Dispose of any waste fuel in compliance with local environmental regulations.

## 1.13.9 Cooling system

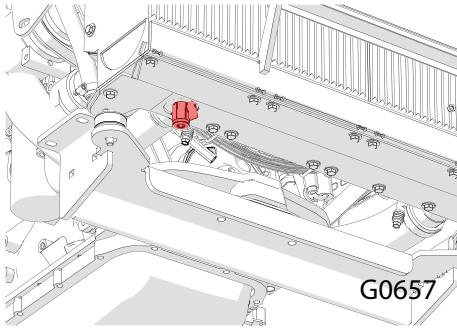

Fig. 21 Coolant, draining

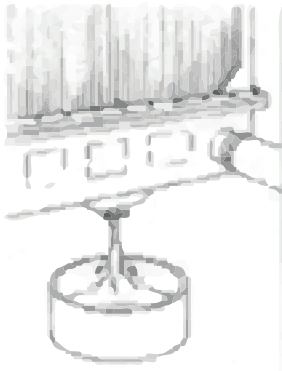

Fig. 22 Coolant, draining

### Coolant, draining

1. Switch off the engine and cut the main power supply.
2. Remove the filler cap from the cooling system's expansion tank.
3. Open all drainage points and drain the coolant from the radiator and engine block. There is one drain tap under the radiator and one drain plug under the coolant intake on the engine block.
4. Check that all the coolant has drained off.
5. Check the condition of the hoses and clamps, and that the radiator does not leak and replace and clean if necessary.

#### NOTICE

Ensure that all coolant is drained!

Any deposits inside the tap/plug must be cleaned away, otherwise there is a risk that some coolant might remain and cause frost damage.

#### NOTICE

The cooling system must be properly filled to prevent air pockets. While filling, the air must be bled out through the cooling channels; wait 2 or 3 minutes to allow all the air to vent the system.

### Cooling system, cleaning

#### NOTICE

Use 0.5 kg of sodium carbonate per 23 litres of water

1. Fill the system with a mixture of sodium carbonate and water.
2. Start and run the engine for 5 minutes with coolant temperature above 80°C. Switch off the engine and drain the cooling system.
3. Fill up the cooling system with clean water.
4. Start and run the engine for 5 minutes with coolant temperature above 80°C. Switch off the engine and drain the cooling system.
5. When the cooling system is entirely clean of all dirt, close the drain taps and plugs.

6. Pour the coolant into the expansion tank's filling opening so that the level reaches the middle of the sight glass. The engine must not be started until the system has been bled and is completely filled.
7. Refit the filler cap and start the engine when the cooling system is completely bled and filled. Open all the heater controls so that air is bled from the heating system.
8. Stop the engine after about an hour and check the coolant level, and top up if necessary.

### NOTICE

Do not fit the filler cap on the expansion tank when cleaning the cooling system. The engine must be run with the cap off during this process.

### NOTICE

If the water that drains off is still dirty, the system must be flushed through until the water that runs off is clean.

### NOTICE

Use only the recommended coolant. Never use only water as a coolant, as this may cause corrosion of the cooling system.

## Mixing coolant

The mixing and monitoring of coolant in liquid-cooled engines is especially important because corrosion, cavitation and freezing can lead to engine damage. The coolant is prepared by mixing an antifreeze with the cooling water. The cooling system must be monitored regularly. The coolant level and the concentration of coolant should both be checked. The concentration of the coolant can be checked with a commercially available tester (refractometer).

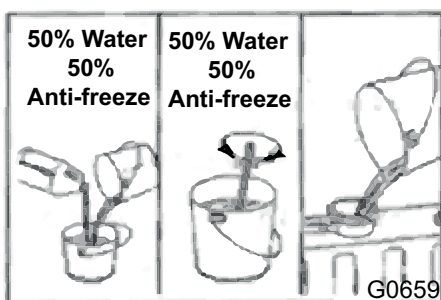

Fig. 23 Coolant, mixing

## Coolant, filling

### NOTICE

It is vital that the system is filled with the right concentration and volume of coolant. Mix it in a separate clean container before filling the cooling system. Make sure the liquids are thoroughly mixed.

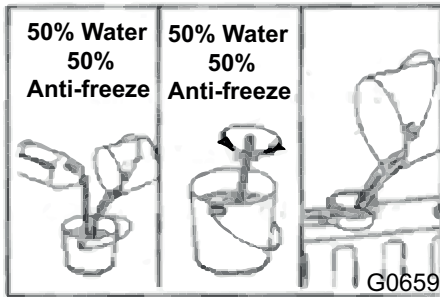

Fig. 24 Coolant, filling

1. Pour the coolant into the expansion tank's filling opening so that the level reaches the middle of the sight glass. **The engine must not be started until the system has been bled and is completely filled.**
2. Refit the filler cap and start the engine when the cooling system is completely bled and filled. Open all the heater controls so that air is bled from the heating system.
3. Stop the engine after about an hour and check the coolant level, and top up if necessary.

Cummins recommends a mix of 50% water and 50% glycol.

\*) Volume of cooling system, see 1.3 *Volume specifications*, page 4.

Use either propylene glycol or ethylene glycol as an antifreeze. For the mixing ratio, see the relevant packaging.

### NOTICE

Do not mix ethylene glycol and propylene glycol. If you have the slightest doubt, pour out, clean and refill with a new mixture.

## Coolant hoses, inspection

Check all the coolant hoses for signs of cracks, chafing damage and collapse.

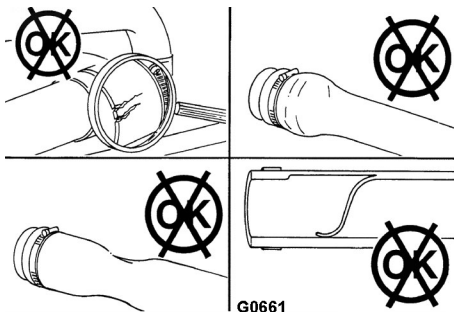

Fig. 25 Coolant hoses, inspection



## 1.13.10 Air conditioning system

### Replacing fresh air filter

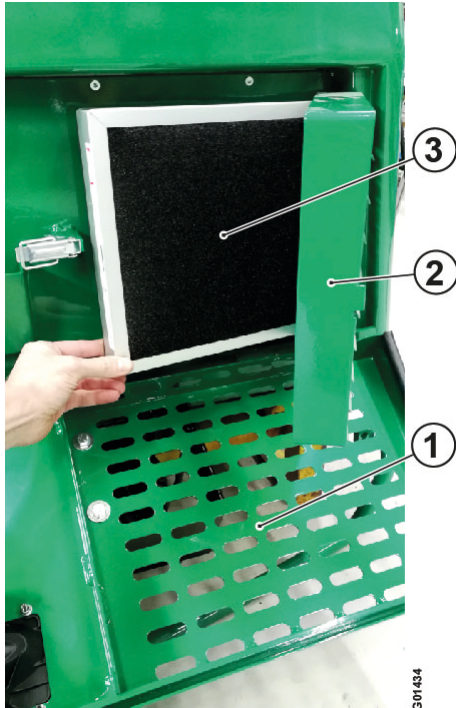

Fig. 26 Fresh air filter

The air conditioning system's fresh air filter is located on the left-hand side of the cab, behind the rear side hatch.

Fold down the rear side hatch (1) and open the cover (2) protecting the fresh air filter.

Remove the old fresh air filter (3) and insert a new fresh air filter.

### Replacement of recirculation filter

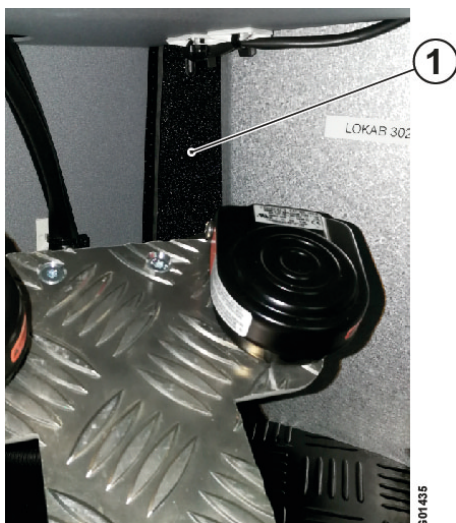

Fig. 27 Recirculation filter

The air conditioning system's recirculation filter (1) is located in the rear left-hand corner of the cab, behind the drive pedal, and may easily be replaced without removing any other part.

## 1.13.11 Air filtration system

### Replacing filter cartridges and safety filters

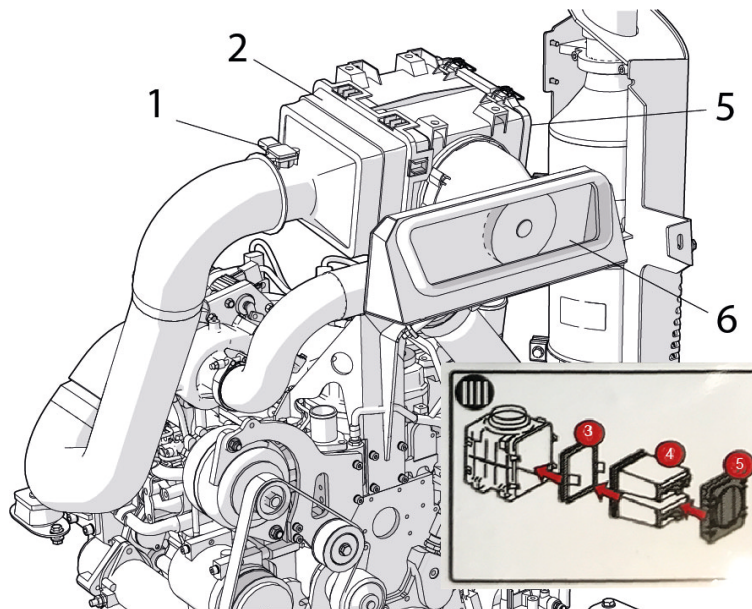

Fig. 28 Air filtration system

- |                                    |                                       |
|------------------------------------|---------------------------------------|
| 1. Air filter indicator            | 4. Outer air filter, filter cartridge |
| 2. Air filter holder               | 5. Filter cover                       |
| 3. Inner air filter, safety filter | 6. Intake with grid                   |

1. Open the three fasteners.
2. Remove the filter cover and remove the filter cartridge.
3. Pull out the safety filter and insert a new one.
4. Insert a new filter cartridge, refit the filter cover and lock using the fasteners.

#### NOTICE

Never run the engine without an air filter. The intake air must be filtered to prevent dirt and particles from being sucked into the engine and causing unnecessary wear.

Carry out regular visual inspections of the air hoses for signs of hose wear, damage to the pipes, loose clamps and leaks that may cause engine damage.

Replace damaged hoses and tighten loose clamps to 8 Nm to prevent leakage.

Check also that pipes and hoses do not show signs of rust; rust flakes and dust may get into the engine with the intake

air and cause damage. Remove and clean parts if  
necessary.

## 1.13.12 Intercooler

### Intercooler, inspection

Check that the intercooler's cooling fins are not blocked by dust or rubbish, and clean if necessary with compressed air.

#### NOTICE

Do not use a high-pressure washer with too high pressure to clean the intercooler's cooling fins.

Also check the intercooler for signs of leakage, cracks, holes or other damage.

### Intercooler pipe, inspection

Check the intercooler pipe and intercooler hoses for signs of leakage, cracks, holes and loose connections. Tighten the hose clamps if necessary.

## 1.13.13 Hydraulic system

### Hydraulic oil

#### Sampling and analysis of condition of hydraulic oil



G01462

Fig. 29 Sampling package for hydraulic oil

Gremo recommends that the condition of the hydraulic oil is checked by means of oil sampling every 1,000 operating hours during the entire lifetime of the machine. This is to minimise the number of oil changes, maximise performance and minimise maintenance costs.

During the warranty period it is of the greatest importance, and a requirement, that an oil sample is taken and sent for analysis 200 operating hours before the next warranty service is due, i.e. after 800 and 1,800 operating hours.

If this is not done, the power output of the diesel engine is limited until the sample has been analysed and approved or the hydraulic oil has been replaced.

You can order the sampling package for hydraulic oil from your retailer or from Gremo AB.

#### Sampling, hydraulic oil

##### NOTICE

Make sure the area around the connections is clean before the oil sample is taken.

Dirt particles can damage the machine and contaminate the oil sample.



G01460

Fig. 30 The outlet is located next to the hydraulic system's off-line filter.

1. Start and warm the machine so that the hydraulic oil reaches operating temperature. Allow the machine to idle.
2. Open the outlet (A) and connect the hose to the outlet.
3. Drain a small quantity of hydraulic oil (2-3 dl) into a container, in order to remove any impurities from the connection.
4. Then fill the sampling bottle completely with hydraulic oil, taking care that no remaining dirt particles are included. Close the bottle carefully.
5. Fill in the accompanying "GREMO Hydraulic oil analysis" card which is included in the sampling package, and send the hydraulic oil for analysis.

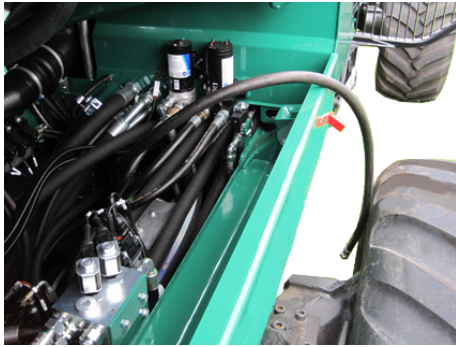

Fig. 31 Draining the hydraulic tank

## Changing hydraulic oil

1. Loosen the left-hand side guard under the hydraulic tank.
2. In the chassis there is a 1/2" hydraulic hose connected to the bottom of the hydraulic tank and plugged into the free end.
3. Pull out the hose and insert it in a large enough container. Remove the end plug to begin emptying.
4. When the tank is empty, refit the plug in the hose and refit the side guard.
5. Refill with new hydraulic oil – see *Instruction Manual*.

## Hydraulic oil return filters

### Replacement of return filters

1. The machine must be switched off by disconnecting the main power circuit.
2. Unscrew the covers on the return filters (F and G in the figure) and lift up the filter cartridges with filter inserts.
3. Pull out the filter insert from the filter cartridges.
4. Put the filter cartridges and filter inserts in a container to let the oil drain off.
5. Clean the filter cartridges inside and out.
6. Insert the new filter inserts into the filter cartridges.
7. Insert the filter cartridges in the tank and screw the covers back in place.
8. Dispose of oil and filters as hazardous waste.

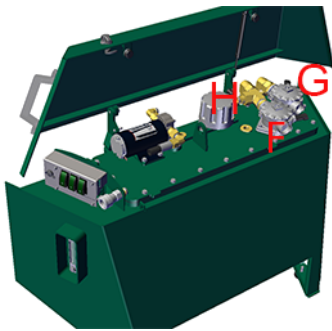

Fig. 32 Replacement of hydraulic oil filters

### NOTICE

Make sure the area around the filter is clean when replacing the filter. Dirt particles might otherwise contaminate the hydraulic system, which can result in damage to the hydraulic components in the hydraulic system.

## Breather filter hydraulic oil tank

### Replacement of breather filters

Replacing breather filter (H), hydraulic oil tank

1. Switch off the engine and cut the main power supply.
2. Unscrew the breather filter.
3. Insert a new breather filter.

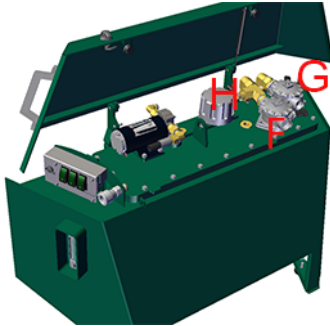

Fig. 33 Breather filter (H)

## Off-line filter hydraulic oil

### Replacement of off-line filter hydraulic oil

1. Switch off the engine and cut the main power supply.
2. Place a container under the off-line filter.
3. Remove the cover.
4. Pull out the filter insert, place the filter cartridge in a container and let the hydraulic oil drain off.
5. Insert the new filter insert and put the cover back on the off-line filter.

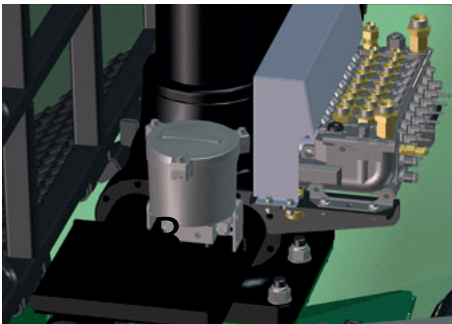
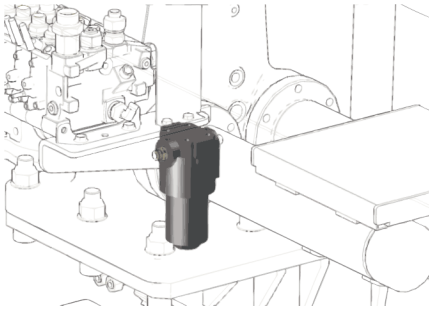

Fig. 34 Replacement of off-line filter, hydraulic oil

### NOTICE

Make sure the area around the filter is clean when replacing the filter. Dirt particles might otherwise contaminate the hydraulic system, which can result in damage to the hydraulic components in the hydraulic system.



*Fig. 35 Replacing pilot filter crane control*

## Replacing pilot filter crane control

1. The engine and main power switch must be turned off.
2. Place a container under the filter.
3. Unscrew the filter holder with the pilot filter casing using a 36 mm hex wrench.
4. Clean the container.
5. Insert a new filter and screw the filter holder in place with a 36 mm hex wrench. Check that the filter holder seals tightly.

### NOTICE

Dispose of the filter and residual oil as hazardous waste.

## Replacement of filter for transmission pump

### NOTICE

Make sure the area around the filter is clean when replacing the filter. Dirt particles might otherwise contaminate the hydraulic system, which can result in damage to the hydraulic components in the hydraulic system.

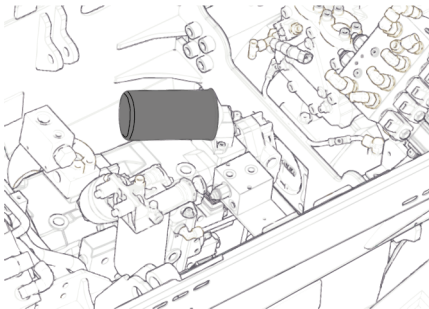

*Fig. 36 Replacement of filter for transmission pump*

1. The engine and main power switch must be turned off.
2. Use absorbent paper or similar to mop up any spilled oil. (The location of the filter makes it impossible to use a container to collect the oil).
3. Remove the hydrostatic filter using a filter wrench.
4. Dispose of oil and filters as hazardous waste.
5. Moisten the new filter's O-ring with clean hydraulic oil.
6. Screw in the new filter so that it fits close, and then tighten it a further half turn by hand.
7. After starting, check that there are no leaks.



## 1.13.14 Transmission system and gearbox

### General

#### Component position

The gearbox in Gremo 1050F4 is a mechanical transmission dropbox with two speed registers. The gearbox has two gears and develops a variable torque that is easily controlled using the potentiometer in the left panel.

This section describes how to check and replace the gearbox oil, as well as the gearbox sensor as presented in the GreControl control system.

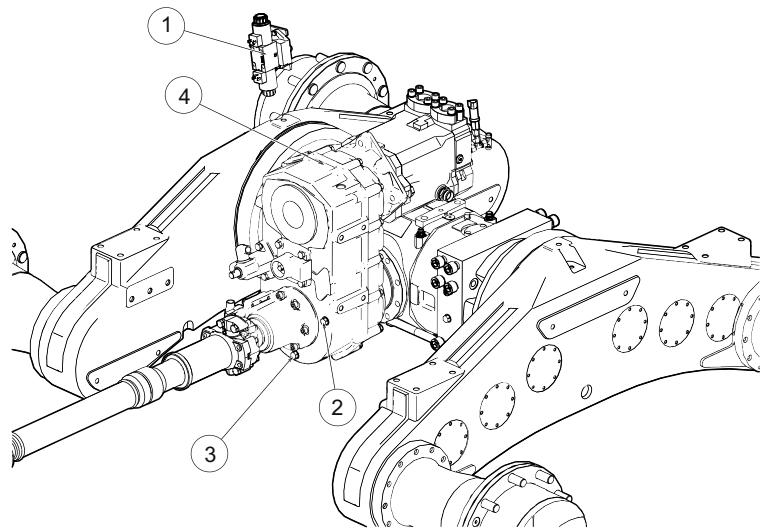

*Fig. 37 Gearbox*

1. Gear valve
2. Level plug
3. Drain plug
4. Filling and dipstick

## Transmission oil, change and level check

### NOTICE

The transmission should never be overfilled!

See Fig. 37 *Gearbox*, page 45.

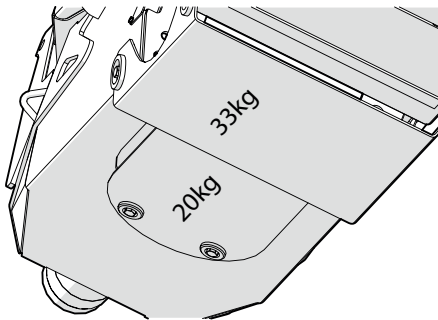
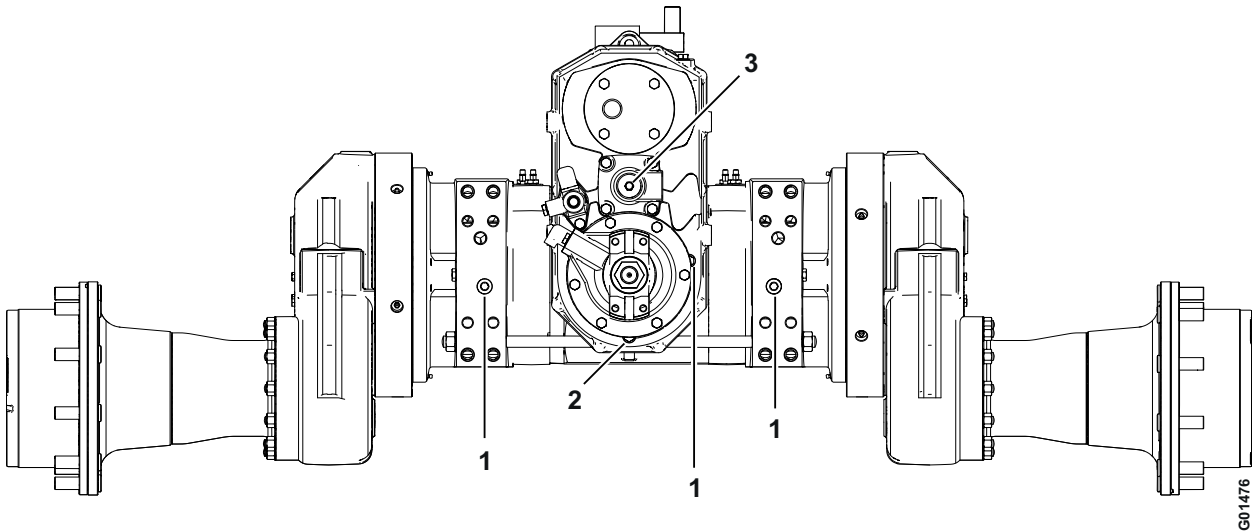

Fig. 38 Level check, transmission oil

1. Run the engine until the transmission oil is hot.
2. Switch off the engine and disconnect the main power supply.
3. Lift out the dipstick (item 4 in the illustration above) at the upper end of the differential and read the oil level or remove the guard plate behind the front axle (20 kg) (2 x M16/Socket 24).
4. Unscrew the level plug/filling plug (item 2 in the illustration above) (wrench width 17). Have a container and clean cloth at hand.
5. Check the level in the opening (item 2 in the illustration above).
6. Fill with gearbox oil (see 1.5 *Oil, requirement specification*, page 5) as required from the filling plug.
7. Check the oil level again.
8. Clean the plug and check its washer.
9. Replace the level plug.
10. Check for leaks.
11. Insert and refit the guard plate.

## Bogie axle

### Component position



*Fig. 39 Bogie axle, component position*

- 1. Drain and level control plug
- 2. Drain plug
- 3. Bleeding

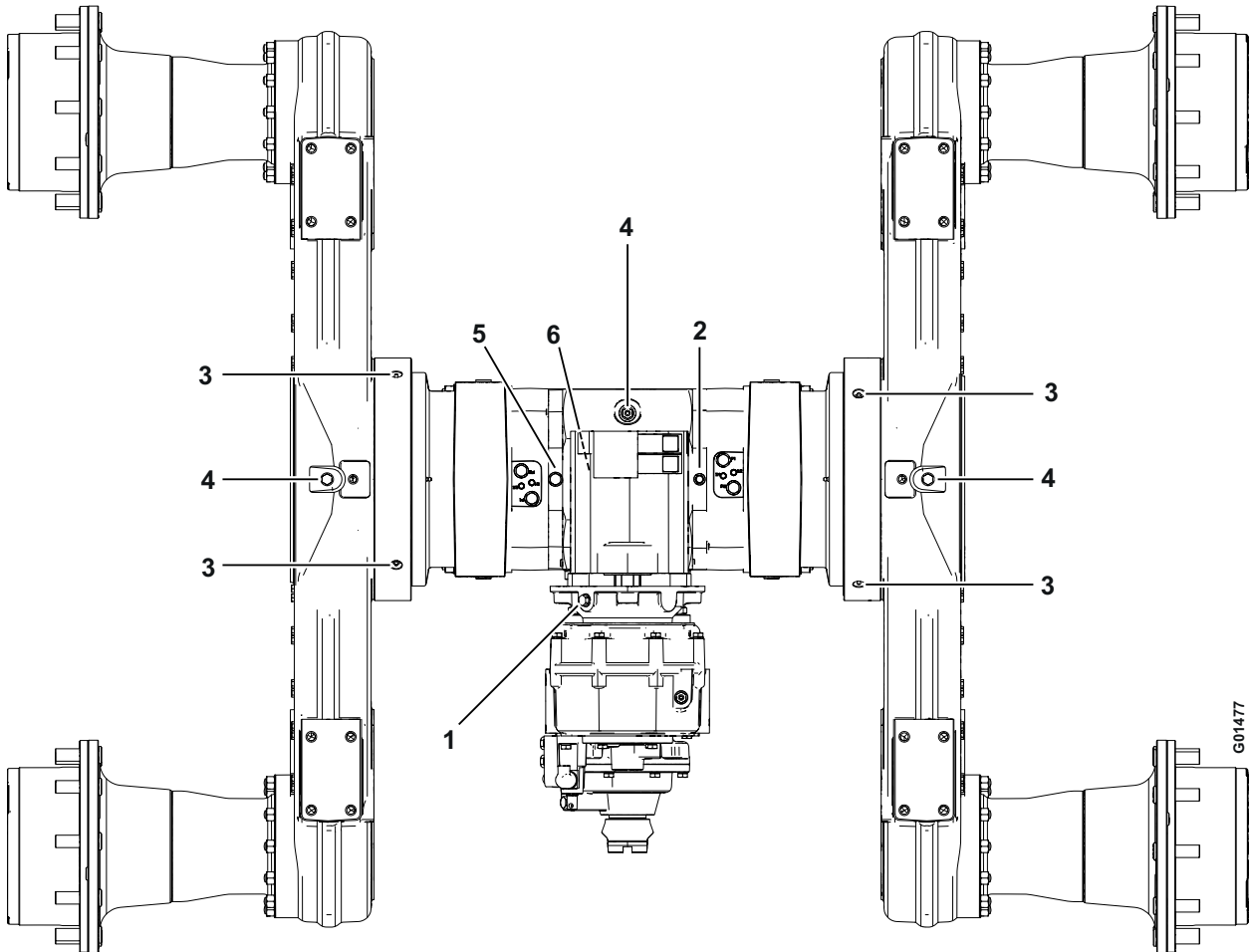

Fig. 40 Bogie axle, component position

- |                                 |   |
|---------------------------------|---|
| 1. Drain and level control plug | 5. Connection for hydraulically operated differential lock (working pressure 15-30 bar) |
| 2. Bleeding                     | 6. Sensor, differential indication  |
| 3. Grease nipple                |   |
| 4. Drain plug                   |   |

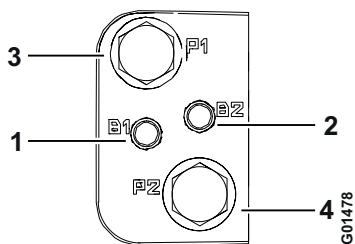
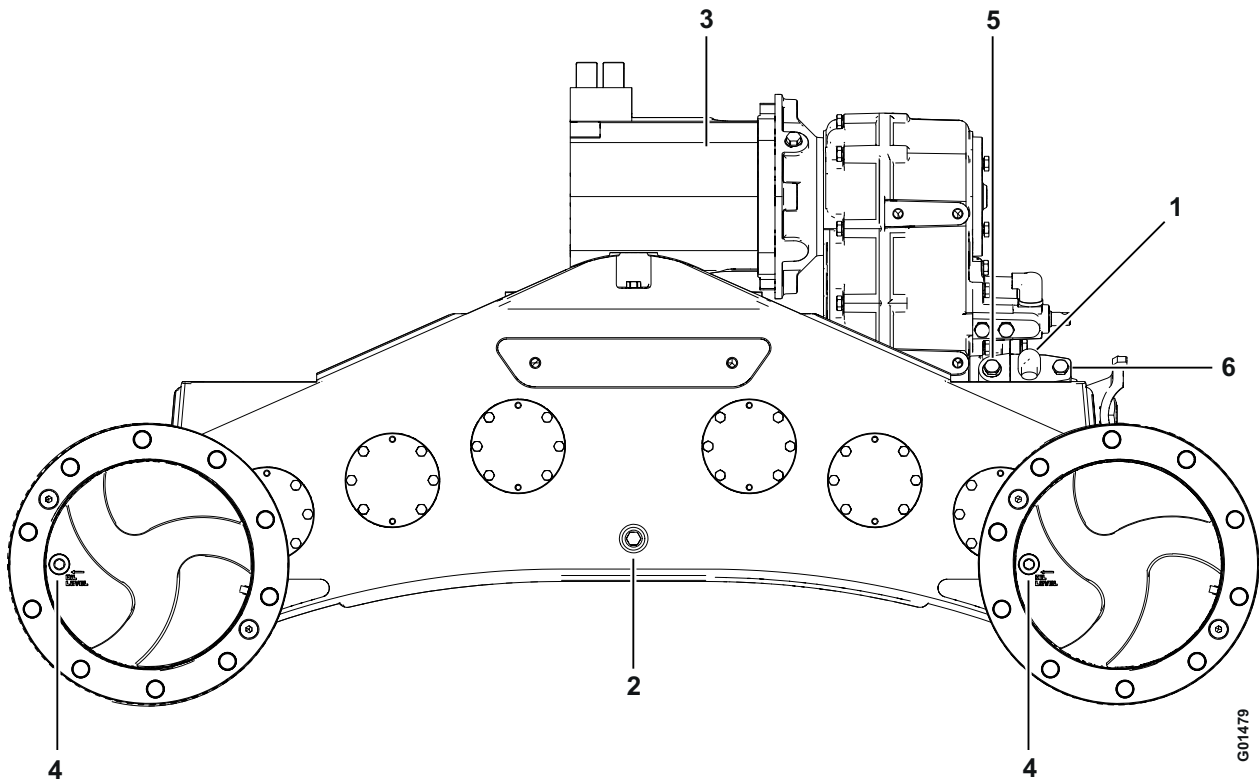

Fig. 41 Bogie axle, component position

- |  |  |
|--|--|
| 1. Air bleeding screw for brake                                    | 4. Connection for working brake cable (max 80 bar) |
| 2. Air bleeding screw for brake                                    |  |
| 3. Connection for parking brake cable (working pressure 15-30 bar) |  |



*Fig. 42 Bogie axle, component position*

- |  |  |
|--|--|
| 1. Sensor, all-wheel drive   | 5. Release pressure all-wheel drive (10-30 bar)    |
| 2. Filling and level control plug  | 6. Connection pressure all-wheel drive (10-30 bar) |
| 3. Hydraulic engine  |  |
| 4. Drain (when plug is in 6 o'clock position) and level control plug (when plug is in 9 o'clock or 3 o'clock position) |  |

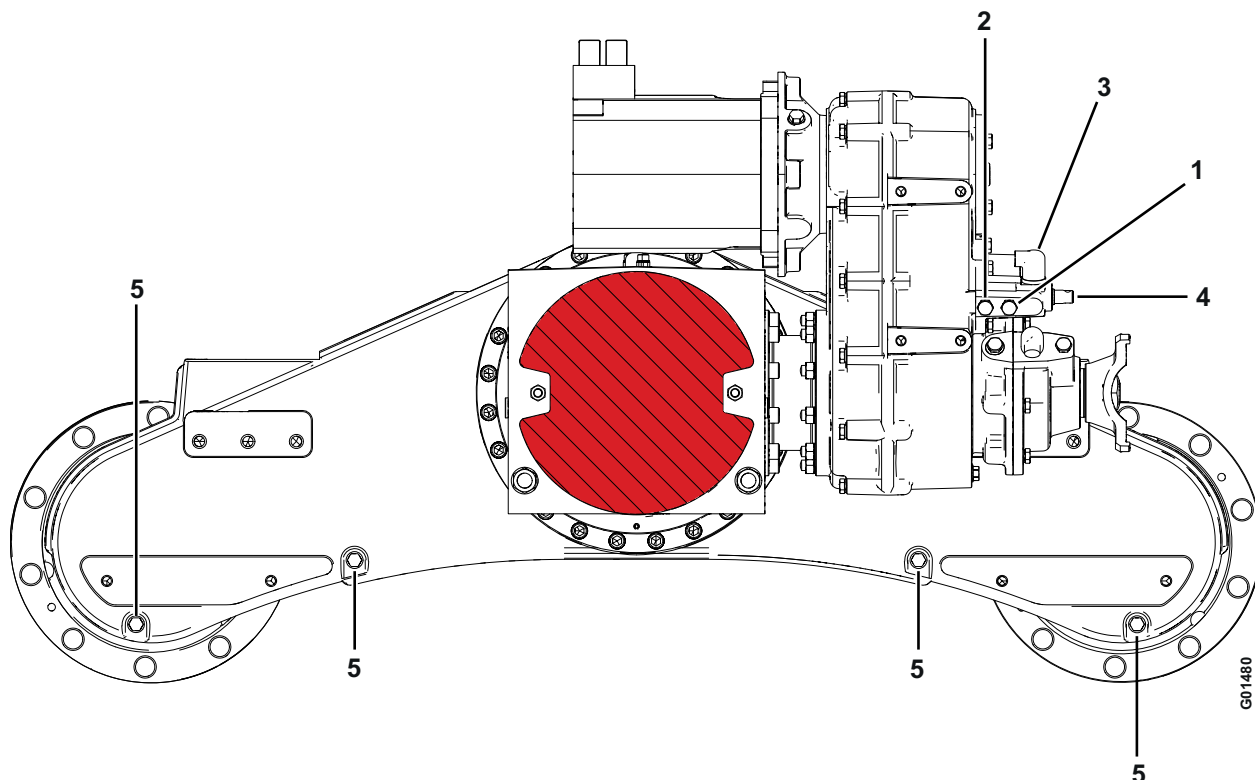

Fig. 43 Bogie axle, component position

- |   |                                       |
|---|---------------------------------------|
| 1. Connection for hydraulic gear 1 (requires pressure of 12-35 bar) | 3. Sensors, gear indication           |
| 2. Connection for hydraulic gear 2 (requires pressure of 12-35 bar) | 4. Manual control of neutral position |
|   | 5. Drain plug                         |

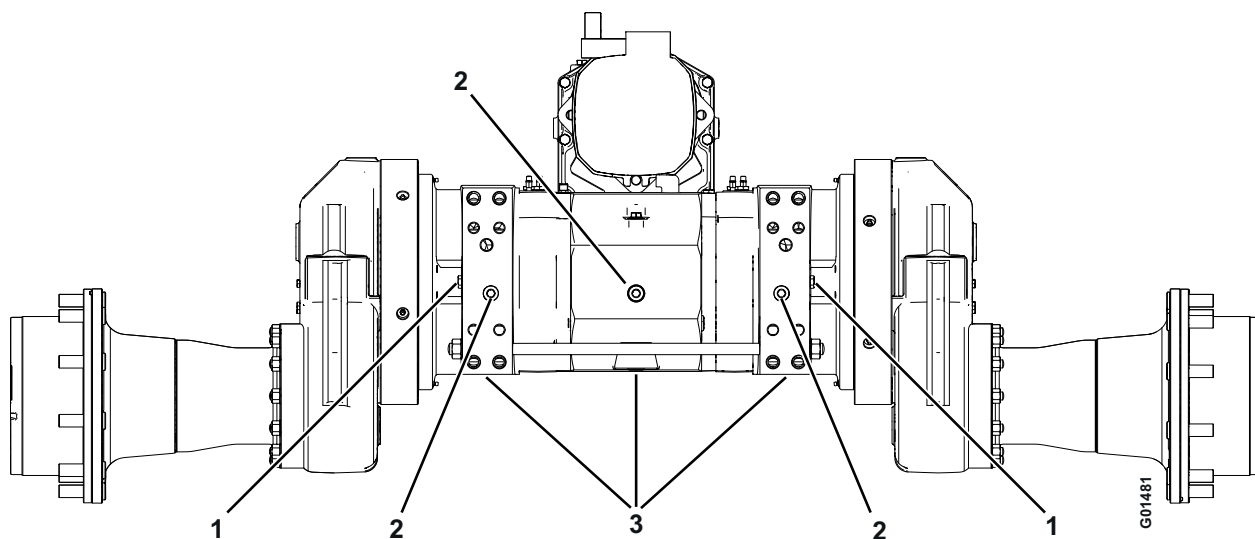

Fig. 44 Bogie axle, component position

- |                                 |               |
|---------------------------------|---------------|
| 1. Release screw, parking brake | 3. Drain plug |
| 2. Drain and level control plug |               |

## Oil level check in bogie axles

### Level check

Each bogie axle has seven separate sections containing oil where the oil level must be checked separately. (4 hub reductions, 2 bogie housings and the differential)

See Fig. 39 *Bogie axle, component position*, page 47.

### NOTICE

The machine must be parked on a level surface when the oil is changed, and particularly when the oil level is being checked.

### The differential

Check the level by loosening the plug (pos. 6) using a 17 mm socket and lift up the dipstick. Read the level.

You can also loosen the level plugs (pos. 7) using a 17 mm socket. Check that the oil is level with the bottom of the opening.

Top up if necessary with the correct grade of oil, see 1.5 *Oil, requirement specification*, page 5.

### Bogie housing

Check the level by loosening the level plug (pos. 5). If the level is below the lower edge of the opening fill up with oil at the top of the bogie housing (pos 9).

Top up with the correct grade of oil, see 1.5 *Oil, requirement specification*, page 5.

### Hub reduction

Run the machine so that the plug (pos. 4) in the hub reduction is 'parallel' to the mark or in the 9 or 3 o'clock position. +1 cm up.

Loosen the plug and check the level.

Top up with the correct grade of oil, see 1.5 *Oil, requirement specification*, page 5.

Screw in the plug, and check the seal is correctly fit.

Repeat the steps on the remaining hub reductions.

## 1.13.15 Winch

### Winch gearbox, level check of gear oil

The oil level in the winch gearbox is checked by means of the plug (1).

Remove the plug and check that the oil level is at the lower edge of the opening. If necessary, top up with oil through the same opening - see 1.5 *Oil, requirement specification*, page 5.

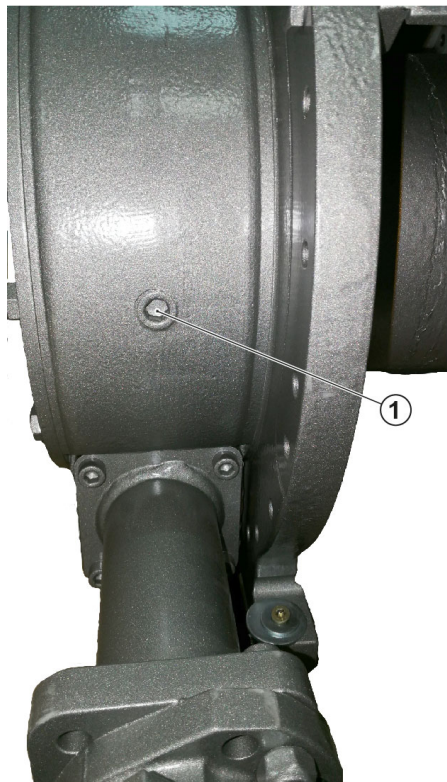

Fig. 45 Winch

00145



## **2 Service and maintenance during the warranty period**

This chapter contains:

1. Service and maintenance during the warranty period
2. Warranty service reports and Error report forms

## 2.1 Report, service during the warranty period after 100 hours of operation

### Machine information

Machine number:

\_\_\_\_\_

### Machine owner

### Telephone number

Machine:

\_\_\_\_\_

Operator:

### Replacement

- Fuel filter
- Fuel prefilter
- Air filter (only in the event of an alarm being triggered)
- Air filter safety insert (only in the event of an alarm being triggered)
- Gearbox oil
- Return oil filter for working hydraulics
- Return oil filter for hydrostat
- Hydrostatic pump filter
- Pilot filter for crane valve
- Oil in the crane base

### Lubrication

- All lubrication points

### Check

- Oil level, diesel engine, see 1.11 *Daily maintenance (every 8-10 operating hours)*, page 16
- Coolant level, see 1.11 *Daily maintenance (every 8-10 operating hours)*, page 16
- Crankcase ventilation, diesel engine
- Air inlet hoses, diesel engine
- Hydraulic oil level
- Leakage, general (air, water, oil)
- Fire extinguishing equipment
- Grapple
- Tyres, pressure and condition
- Hydraulic hoses
- Wheel bolts
- Crane axles and interlocks
- Extension chains
- Oil level in winch gearbox

## 2.2 Report, service during the warranty period after 100 hours of operation (cont'd.)

### Check

- Machine cleanliness
- Condition and tension of the drive belt
- Coolant hoses
- Air filter dust collector
- Battery connections
- Oil level, hub reductions
- Oil level, differentials
- Oil level, bogie cases
- Oil level, winch gearbox
- Brake function, traffic brake
- Brake function, working brake
- Brake function, parking brake
- Re-tightening of the upper and lower expander bolts in the articulated joint
- Pressure setting for crane
- Tightening the screw joints
- Sign-off for Warranty Service 100 h in GreControl

### The report must be submitted to:

GreMO AB, FAO: SERVICE

Box 51

311 51 ÄTRAN

### Service information

Service performed date: \_\_\_\_\_

Service performed by: \_\_\_\_\_

*Authorised service dealer*

Service approved: \_\_\_\_\_

*Customer signature*

## 2.3 Fault report 100 h

|  |
|--|
| <p><b>Machine information</b></p> <p>Machine number: _____</p> <p><b>Machine owner</b></p> |
|--|

Electrical system:

---

---

---

---

Hydraulics:

---

---

---

---

---

Hoses:

---

---

---

---

Tyres:

---

---

---

---

Chassis:

---

---

---

---

Miscellaneous:

---

---

---

## 2.4 Report, service during the warranty period after 100 hours of operation Copy Customer's Copies

**Machine information**

Machine number:  
\_\_\_\_\_

**Machine owner**

**Telephone number**

Machine:  
\_\_\_\_\_

Operator:

**Replacement**

Fuel filter

Fuel prefilter

Air filter (only in the event of an alarm being triggered)

Air filter safety insert (only in the event of an alarm being triggered)

Gearbox oil

Return oil filter for working hydraulics

Return oil filter for hydrostat

Hydrostatic pump filter

Pilot filter for crane valve

Oil in the crane base

**Lubrication**

All lubrication points

**Check**

Oil level, diesel engine, see 1.11 *Daily maintenance (every 8-10 operating hours)*, page 16

Coolant level, see 1.11 *Daily maintenance (every 8-10 operating hours)*, page 16

Crankcase ventilation, diesel engine

Air inlet hoses, diesel engine

Hydraulic oil level

Leakage, general (air, water, oil)

Fire extinguishing equipment

Grapple

Tyres, pressure and condition

Hydraulic hoses

Wheel bolts

Crane axles and interlocks

Extension chains

Oil level in winch gearbox

## 2.5 Report, service during the warranty period after 100 hours of operation (cont'd.) Copy Customer's Copies

| Check                    |  |
|--------------------------|--|
| <input type="checkbox"/> | Machine cleanliness  |
| <input type="checkbox"/> | Condition and tension of the drive belt                                      |
| <input type="checkbox"/> | Coolant hoses  |
| <input type="checkbox"/> | Air filter dust collector  |
| <input type="checkbox"/> | Battery connections  |
| <input type="checkbox"/> | Oil level, hub reductions  |
| <input type="checkbox"/> | Oil level, differentials   |
| <input type="checkbox"/> | Oil level, bogie cases   |
| <input type="checkbox"/> | Oil level, winch gearbox   |
| <input type="checkbox"/> | Brake function, traffic brake  |
| <input type="checkbox"/> | Brake function, working brake  |
| <input type="checkbox"/> | Brake function, parking brake  |
| <input type="checkbox"/> | Re-tightening of the upper and lower expander bolts in the articulated joint |
| <input type="checkbox"/> | Pressure setting for crane   |
| <input type="checkbox"/> | Tightening the screw joints  |
| <input type="checkbox"/> | Sign-off for Warranty Service 100 h in GreControl                            |

|  |
|--|
| <p><b>The report must be submitted to:</b></p> <p>Greco AB, FAO: SERVICE</p> <p>Box 51</p> <p>311 51 ÄTRAN</p> |
|--|

|   |
|---|
| <p><b>Service information</b></p> <p>Service performed date: _____</p> <p>Service performed by: _____</p> <p><i>Authorised service dealer</i></p> <p>Service approved: _____</p> <p><i>Customer signature</i></p> |
|---|

## 2.6 Fault report 100 h Copy Customer's Copies

|  |
|--|
| <p><b>Machine information</b></p> <p>Machine number: _____</p> <p><b>Machine owner</b></p> |
|--|

Electrical system:

---

---

---

---

Hydraulics:

---

---

---

---

---

Hoses:

---

---

---

---

Tyres:

---

---

---

---

Chassis:

---

---

---

---

Miscellaneous:

---

---

---

## 2.7 Report, service during the warranty period after 500 hours of operation

### Machine information

Machine number: \_\_\_\_\_

### Machine owner

### Telephone number

Machine: \_\_\_\_\_

Operator: \_\_\_\_\_

### Replacement

- Engine oil and filter
- Fuel filter
- Fuel prefilter
- Air filter (only in the event of an alarm being triggered)
- Air filter safety insert (only in the event of an alarm being triggered)
- Fresh air filter, air conditioning unit
- Recirculation filter, air conditioning unit

### Lubrication

- All lubrication points

### Cleaning

- Clean the machine, see 1.11 *Daily maintenance (every 8-10 operating hours)*, page 16.
- Vibration damper, brake lining
- Heating element
- Condensor, air conditioning unit

### Check

- Crankcase ventilation, diesel engine, see 1.11 *Daily maintenance (every 8-10 operating hours)*, page 16
- Air inlet hoses, diesel engine, see 1.11 *Daily maintenance (every 8-10 operating hours)*, page 16
- Hydraulic oil level, see 1.11 *Daily maintenance (every 8-10 operating hours)*, page 16
- Leakage, general, see 1.11 *Daily maintenance (every 8-10 operating hours)*, page 16
- Fire extinguishing, see 1.11 *Daily maintenance (every 8-10 operating hours)*, page 16 and 1.12 *Inspection every 50 hours of operation or every week*, page 19
- Grapple, see 1.11 *Daily maintenance (every 8-10 operating hours)*, page 16
- Tyres, pressure and condition, see 1.11 *Daily maintenance (every 8-10 operating hours)*, page 16 and 1.12 *Inspection every 50 hours of operation or every week*, page 19
- Drive belt, engine, see 1.12 *Inspection every 50 hours of operation or every week*, page 19
- Hydraulic hoses, see 1.12 *Inspection every 50 hours of operation or every week*, page 19
- Wheel nuts, see 1.12 *Inspection every 50 hours of operation or every week*, page 19
- Crane axles and interlocks, see 1.12 *Inspection every 50 hours of operation or every week*, page 19
- Telescopic extension chains, see 1.12 *Inspection every 50 hours of operation or every week*, page 19
- Oil level, winch gearbox, see 1.12 *Inspection every 50 hours of operation or every week*, page 19



## 2.8 Report, service during the warranty period after 500 hours of operation (cont'd.)

### Check

- Oil level, hub reductions
- Oil level, differential
- Oil level, gearbox
- Oil level, bogie cases
- Oil level, winch gearbox
- Fan heating element
- Cooling hoses (cracks, hose clamps, etc.)
- Coolant, frost protection
- Air filter dust collector
  
- Battery, fluid level, poles and connections
- Re-tightening of the upper and lower expander bolts in the articulated joint
- Pressure setting for crane
  
- Brake function, traffic brake
- Brake function, working brake
- Brake function, parking brake
  
- Inspection of crane
- Check function of air conditioning system.
- Sign-off for Warranty Service in GreControl

### Service information

Service performed date \_\_\_\_\_

Service performed by:

\_\_\_\_\_  
*Machine owner/Authorised service dealer*

### The report must be submitted to

Gremo AB, FAO: SERVICE

Box 44

311 51 ÄTRAN

## 2.9 Fault report 500 h

|  |
|--|
| <p><b>Machine information</b></p> <p>Machine number: _____</p> <p><b>Machine owner</b></p> |
|--|

Electrical system:

---

---

---

---

Hydraulics:

---

---

---

---

---

Hoses:

---

---

---

---

Tyres:

---

---

---

---

Chassis:

---

---

---

---

Miscellaneous:

---

---

---

## 2.10 Report, service during the warranty period after 500 hours of operation Copy Customer's Copies

**Machine information**

Machine number: \_\_\_\_\_

**Machine owner**

**Telephone number**

Machine: \_\_\_\_\_

Operator: \_\_\_\_\_

**Replacement**

Engine oil and filter

Fuel filter

Fuel prefilter

Air filter (only in the event of an alarm being triggered)

Air filter safety insert (only in the event of an alarm being triggered)

Fresh air filter, air conditioning unit

Recirculation filter, air conditioning unit

**Lubrication**

All lubrication points

**Cleaning**

Clean the machine, see 1.11 *Daily maintenance (every 8-10 operating hours)*, page 16.

Vibration damper, brake lining

Heating element

Condensor, air conditioning unit

**Check**

Crankcase ventilation, diesel engine, see 1.11 *Daily maintenance (every 8-10 operating hours)*, page 16

Air inlet hoses, diesel engine, see 1.11 *Daily maintenance (every 8-10 operating hours)*, page 16

Hydraulic oil level, see 1.11 *Daily maintenance (every 8-10 operating hours)*, page 16

Leakage, general, see 1.11 *Daily maintenance (every 8-10 operating hours)*, page 16

Fire extinguishing, see 1.11 *Daily maintenance (every 8-10 operating hours)*, page 16 and 1.12 *Inspection every 50 hours of operation or every week*, page 19

Grapple, see 1.11 *Daily maintenance (every 8-10 operating hours)*, page 16

Tyres, pressure and condition, see 1.11 *Daily maintenance (every 8-10 operating hours)*, page 16 and 1.12 *Inspection every 50 hours of operation or every week*, page 19

Drive belt, engine, see 1.12 *Inspection every 50 hours of operation or every week*, page 19

Hydraulic hoses, see 1.12 *Inspection every 50 hours of operation or every week*, page 19

Wheel nuts, see 1.12 *Inspection every 50 hours of operation or every week*, page 19

Crane axles and interlocks, see 1.12 *Inspection every 50 hours of operation or every week*, page 19

Telescopic extension chains, see 1.12 *Inspection every 50 hours of operation or every week*, page 19

Oil level, winch gearbox, see 1.12 *Inspection every 50 hours of operation or every week*, page 19

## 2.11 Report, service during the warranty period after 500 hours of operation (cont'd.) Copy Customer's Copies

| Check                    |  |
|--------------------------|--|
| <input type="checkbox"/> | Oil level, hub reductions  |
| <input type="checkbox"/> | Oil level, differential  |
| <input type="checkbox"/> | Oil level, gearbox   |
| <input type="checkbox"/> | Oil level, bogie cases   |
| <input type="checkbox"/> | Oil level, winch gearbox   |
| <input type="checkbox"/> | Fan heating element  |
| <input type="checkbox"/> | Cooling hoses (cracks, hose clamps, etc.)                                    |
| <input type="checkbox"/> | Coolant, frost protection  |
| <input type="checkbox"/> | Air filter dust collector  |
| <input type="checkbox"/> | Battery, fluid level, poles and connections                                  |
| <input type="checkbox"/> | Re-tightening of the upper and lower expander bolts in the articulated joint |
| <input type="checkbox"/> | Pressure setting for crane   |
| <input type="checkbox"/> | Brake function, traffic brake  |
| <input type="checkbox"/> | Brake function, working brake  |
| <input type="checkbox"/> | Brake function, parking brake  |
| <input type="checkbox"/> | Inspection of crane  |
| <input type="checkbox"/> | Check function of air conditioning system.                                   |
| <input type="checkbox"/> | Sign-off for Warranty Service in GreControl                                  |

### Service information

Service performed date \_\_\_\_\_

Service performed by:

\_\_\_\_\_  
*Machine owner/Authorised service dealer*

### The report must be submitted to

Gremo AB, FAO: SERVICE

Box 44

311 51 ÄTRAN

## 2.12 Fault report 500 h Copy Customer's Copies

|  |
|--|
| <p><b>Machine information</b></p> <p>Machine number: _____</p> <p><b>Machine owner</b></p> |
|--|

Electrical system:

---

---

---

---

Hydraulics:

---

---

---

---

---

Hoses:

---

---

---

---

Tyres:

---

---

---

---

Chassis:

---

---

---

---

Miscellaneous:

---

---

---

## 2.13 Report, service during the warranty period after 1,000 hours of operation

### Machine information

Machine number: \_\_\_\_\_

### Machine owner

### Telephone number

Machine: \_\_\_\_\_

Operator: \_\_\_\_\_

### Replacement

- Engine oil and oil filter
- Fuel filter
- Fuel prefilter
- Air filter (only in the event of an alarm being triggered)
- Air filter safety insert (only in the event of an alarm being triggered)
- Gearbox oil
- Oil in the differential housing
- Oil in hub reductions
- Hydraulic oil (for negative oil test)
- Return oil filter for working hydraulics
- Return oil filter for hydrostat
- Breather filter hydraulic oil tank
- Hydrostatic pump filter
- Off-line filter
- Pilot filter for crane valve
- Oil in the crane base
- Winch's gearbox oil
- Air conditioning system's fresh air filter
- Air conditioning system's recirculation air filter

### Lubricated

- All lubrication points

### Cleaned

- Vibration damper, brake lining
- Radiator
- Air conditioning system's condensor
- Rotator's magnet plugs (if fitted)

### Sampling

- Oil sample working hydraulics



## 2.14 Report, service during the warranty period after 1,000 hours of operation (cont'd.)

| <b>Checked</b>           |   |
|--------------------------|---|
| <input type="checkbox"/> | Crankcase ventilation, diesel engine, (see Daily checks)                                  |
| <input type="checkbox"/> | Air inlet hoses, diesel engine, (see Daily checks)  |
| <input type="checkbox"/> | Hydraulic oil level (see Daily checks)  |
| <input type="checkbox"/> | Leakage, fluid sub-systems, (see Daily checks)  |
| <input type="checkbox"/> | Fire extinguishing (See Daily checks + Inspection every 50 hours of operation)            |
| <input type="checkbox"/> | Grapple (see Daily checks)  |
| <input type="checkbox"/> | Tyres, pressure and condition (see Daily checks + Inspection every 50 hours of operation) |
| <input type="checkbox"/> | Engine's drive belt (See Inspection every 50 hours of operation)                          |
| <input type="checkbox"/> | Hydraulic hoses (See Inspection every 50 hours of operation)                              |
| <input type="checkbox"/> | Wheel bolts (See Inspection every 50 hours of operation)                                  |
| <input type="checkbox"/> | Crane axles and interlocks (See Inspection every 50 hours of operation)                   |
| <input type="checkbox"/> | Boom extension chains (See Inspection every 50 hours of operation)                        |

| <b>Checked</b>           |  |
|--------------------------|--|
| <input type="checkbox"/> | Machine cleanliness  |
| <input type="checkbox"/> | Oil level, bogie cases   |
| <input type="checkbox"/> | Belt tensioner   |
| <input type="checkbox"/> | Exhaust system   |
| <input type="checkbox"/> | Radiator fan   |
| <input type="checkbox"/> | Cooling hoses (cracks, hose clamps, etc.)                                    |
| <input type="checkbox"/> | Coolant, antifreeze  |
| <input type="checkbox"/> | Air filter dust collector  |
| <input type="checkbox"/> | Air compressor   |
| <input type="checkbox"/> | Batteries, connections and installation                                      |
| <input type="checkbox"/> | Re-tightening of the upper and lower expander bolts in the articulated joint |
| <input type="checkbox"/> | Pressure setting for crane   |
| <input type="checkbox"/> | Brake function, traffic brake  |
| <input type="checkbox"/> | Brake function, working brake  |
| <input type="checkbox"/> | Brake function, parking brake  |
| <input type="checkbox"/> | Inspection as in Inspection Journal for forestry crane                       |
| <input type="checkbox"/> | Air conditioning function control  |
| <input type="checkbox"/> | Play in articulated steering joint   |
| <input type="checkbox"/> | Wear plate bogie housings  |
| <input type="checkbox"/> | Tightening the screw joints  |
| <input type="checkbox"/> | Sign-off for Warranty Service 1,000 h in GreControl                          |

|   |
|---|
| <p><b>Service information</b></p> <p>Service performed date: _____</p> <p>Service performed by: _____</p> <p><i>Authorised service dealer</i></p> |
| <p>Service approved:</p><br><br><br><br><br><br><br><br><br><br><p><i>Customer signature</i></p>  |

|  |
|--|
| <p><b>The report must be submitted to:</b></p> <p>Gremon AB, Att Service</p> <p>Box 44</p> <p>311 51 ÄTRAN</p> |
|--|



## 2.15 Fault report 1,000 h

|  |
|--|
| <p><b>Machine information</b></p> <p>Machine number: _____</p> <p><b>Machine owner</b></p> |
|--|

Electrical system:

---

---

---

---

Hydraulics:

---

---

---

---

---

---

Hoses:

---

---

---

---

---

Tyres:

---

---

---

---

---

Chassis:

---

---

---

---

---

Miscellaneous:

---

---

---

---

## 2.16 Report, service during the warranty period after 1,000 hours of operation Copy Customer's Copies

|  |
|--|
| <p><b>Machine information</b></p> <p>Machine number: _____</p> <p><b>Machine owner</b></p> |
|--|

|   |
|---|
| <p><b>Telephone number</b></p> <p>Machine: _____</p> <p>Operator: _____</p> |
|---|

|   |
|---|
| <p><b>Replacement</b></p> <p><input type="checkbox"/> Engine oil and oil filter</p> <p><input type="checkbox"/> Fuel filter</p> <p><input type="checkbox"/> Fuel prefilter</p> <p><input type="checkbox"/> Air filter (only in the event of an alarm being triggered)</p> <p><input type="checkbox"/> Air filter safety insert (only in the event of an alarm being triggered)</p> <p><input type="checkbox"/> Gearbox oil</p> <p><input type="checkbox"/> Oil in the differential housing</p> <p><input type="checkbox"/> Oil in hub reductions</p> <p><input type="checkbox"/> Hydraulic oil (for negative oil test)</p> <p><input type="checkbox"/> Return oil filter for working hydraulics</p> <p><input type="checkbox"/> Return oil filter for hydrostat</p> <p><input type="checkbox"/> Breather filter hydraulic oil tank</p> <p><input type="checkbox"/> Hydrostatic pump filter</p> <p><input type="checkbox"/> Off-line filter</p> <p><input type="checkbox"/> Pilot filter for crane valve</p> <p><input type="checkbox"/> Oil in the crane base</p> <p><input type="checkbox"/> Winch's gearbox oil</p> <p><input type="checkbox"/> Air conditioning system's fresh air filter</p> <p><input type="checkbox"/> Air conditioning system's recirculation air filter</p> |
|---|

|   |
|---|
| <p><b>Lubricated</b></p> <p><input type="checkbox"/> All lubrication points</p> |
|---|

|  |
|--|
| <p><b>Cleaned</b></p> <p><input type="checkbox"/> Vibration damper, brake lining</p> <p><input type="checkbox"/> Radiator</p> <p><input type="checkbox"/> Air conditioning system's condensor</p> <p><input type="checkbox"/> Rotator's magnet plugs (if fitted)</p> |
|--|

|  |
|--|
| <p><b>Sampling</b></p> <p><input type="checkbox"/> Oil sample working hydraulics</p> |
|--|



## 2.17 Report, service during the warranty period after 1,000 hours of operation (cont'd.) Copy Customer's Copies

**Checked**

Crankcase ventilation, diesel engine, (see Daily checks)

Air inlet hoses, diesel engine, (see Daily checks)

Hydraulic oil level (see Daily checks)

Leakage, fluid sub-systems, (see Daily checks)

Fire extinguishing (See Daily checks + Inspection every 50 hours of operation)

Grapple (see Daily checks)

Tyres, pressure and condition (see Daily checks + Inspection every 50 hours of operation)

Engine's drive belt (See Inspection every 50 hours of operation)

Hydraulic hoses (See Inspection every 50 hours of operation)

Wheel bolts (See Inspection every 50 hours of operation)

Crane axles and interlocks (See Inspection every 50 hours of operation)

Boom extension chains (See Inspection every 50 hours of operation)

**Service information**

Service performed date: \_\_\_\_\_

Service performed by: \_\_\_\_\_

*Authorised service dealer*

---

Service approved:

\_\_\_\_\_

*Customer signature*

**Checked**

Machine cleanliness

Oil level, bogie cases

Belt tensioner

Exhaust system

Radiator fan

Cooling hoses (cracks, hose clamps, etc.)

Coolant, antifreeze

Air filter dust collector

Air compressor

Batteries, connections and installation

Re-tightening of the upper and lower expander bolts in the articulated joint

Pressure setting for crane

Brake function, traffic brake

Brake function, working brake

Brake function, parking brake

Inspection as in Inspection Journal for forestry crane

Air conditioning function control

Play in articulated steering joint

Wear plate bogie housings

Tightening the screw joints

Sign-off for Warranty Service 1,000 h in GreControl

**The report must be submitted to:**

Greco AB, Att Service

Box 44

311 51 ÄTRAN

## 2.18 Fault report 1,000 h Copy Customer's Copies

**Machine information**

Machine number: \_\_\_\_\_

**Machine owner**

Electrical system:

---

---

---

---

Hydraulics:

---

---

---

---

---

Hoses:

---

---

---

---

Tyres:

---

---

---

---

Chassis:

---

---

---

---

Miscellaneous:

---

---

---

## 2.19 Report, service during the warranty period after 1,500 hours of operation

### Machine information

Machine number: \_\_\_\_\_

### Machine owner

### Telephone number

Machine: \_\_\_\_\_

Operator: \_\_\_\_\_

### Replacement

- Engine oil and filter
- Fuel filter
- Fuel prefilter
- Air filter (only in the event of an alarm being triggered)
- Air filter safety insert (only in the event of an alarm being triggered)
- Fresh air filter, air conditioning unit
- Recirculation filter, air conditioning unit

### Lubrication

- All lubrication points

### Cleaning

- Clean the machine, see 1.11 *Daily maintenance (every 8-10 operating hours)*, page 16.
- Vibration damper, brake lining
- Heating element
- Condensor, air conditioning unit

### Check

- Crankcase ventilation, diesel engine, see 1.11 *Daily maintenance (every 8-10 operating hours)*, page 16
- Air inlet hoses, diesel engine, see 1.11 *Daily maintenance (every 8-10 operating hours)*, page 16
- Hydraulic oil level, see 1.11 *Daily maintenance (every 8-10 operating hours)*, page 16
- Leakage, general, see 1.11 *Daily maintenance (every 8-10 operating hours)*, page 16
- Fire extinguishing, see 1.11 *Daily maintenance (every 8-10 operating hours)*, page 16 and 1.12 *Inspection every 50 hours of operation or every week*, page 19
- Grapple, see 1.11 *Daily maintenance (every 8-10 operating hours)*, page 16
- Tyres, pressure and condition, see 1.11 *Daily maintenance (every 8-10 operating hours)*, page 16 and 1.12 *Inspection every 50 hours of operation or every week*, page 19
- Drive belt, engine, see 1.12 *Inspection every 50 hours of operation or every week*, page 19
- Hydraulic hoses, see 1.12 *Inspection every 50 hours of operation or every week*, page 19
- Wheel nuts, see 1.12 *Inspection every 50 hours of operation or every week*, page 19
- Crane axles and interlocks, see 1.12 *Inspection every 50 hours of operation or every week*, page 19
- Telescopic extension chains, see 1.12 *Inspection every 50 hours of operation or every week*, page 19
- Oil level, winch gearbox, see 1.12 *Inspection every 50 hours of operation or every week*, page 19

## 2.20 Report, service during the warranty period after 1,500 hours of operation (cont'd.)

### Check

- Oil level, hub reductions
- Oil level, differential
- Oil level, gearbox
- Oil level, bogie cases
- Oil level, winch gearbox
- Fan heating element
- Cooling hoses (cracks, hose clamps, etc.)
- Coolant, frost protection
- Air filter dust collector
- Air compressor
- Battery, fluid level, poles and connections
- Re-tightening of the upper and lower expander bolts in the articulated joint
- Pressure setting for crane
- Brake function, traffic brake
- Brake function, working brake
- Brake function, parking brake
- Inspection of forestry crane
- Check function of air conditioning system.
- Sign-off for Warranty Service 1,000 h in GreControl

---

### Service information

Service performed date \_\_\_\_\_

Service performed by:  
\_\_\_\_\_

*Machine owner/Authorised service dealer*

### The report must be submitted to

Greco AB, FAO: SERVICE

Box 44

311 51 ÄTRAN

## 2.21 Fault report 1,500 h

|  |
|--|
| <p><b>Machine information</b></p> <p>Machine number: _____</p> <p><b>Machine owner</b></p> |
|--|

Electrical system:

---

---

---

---

Hydraulics:

---

---

---

---

---

---

Hoses:

---

---

---

---

Tyres:

---

---

---

---

Chassis:

---

---

---

---

Miscellaneous:

---

---

---



## 2.22 Report, service during the warranty period after 1,500 hours of operation Copy Customer's Copies

**Machine information**

Machine number: \_\_\_\_\_

**Machine owner**

**Telephone number**

Machine: \_\_\_\_\_

Operator: \_\_\_\_\_

**Replacement**

Engine oil and filter

Fuel filter

Fuel prefilter

Air filter (only in the event of an alarm being triggered)

Air filter safety insert (only in the event of an alarm being triggered)

Fresh air filter, air conditioning unit

Recirculation filter, air conditioning unit

**Lubrication**

All lubrication points

**Cleaning**

Clean the machine, see 1.11 *Daily maintenance (every 8-10 operating hours)*, page 16.

Vibration damper, brake lining

Heating element

Condensor, air conditioning unit

**Check**

Crankcase ventilation, diesel engine, see 1.11 *Daily maintenance (every 8-10 operating hours)*, page 16

Air inlet hoses, diesel engine, see 1.11 *Daily maintenance (every 8-10 operating hours)*, page 16

Hydraulic oil level, see 1.11 *Daily maintenance (every 8-10 operating hours)*, page 16

Leakage, general, see 1.11 *Daily maintenance (every 8-10 operating hours)*, page 16

Fire extinguishing, see 1.11 *Daily maintenance (every 8-10 operating hours)*, page 16 and 1.12 *Inspection every 50 hours of operation or every week*, page 19

Grapple, see 1.11 *Daily maintenance (every 8-10 operating hours)*, page 16

Tyres, pressure and condition, see 1.11 *Daily maintenance (every 8-10 operating hours)*, page 16 and 1.12 *Inspection every 50 hours of operation or every week*, page 19

Drive belt, engine, see 1.12 *Inspection every 50 hours of operation or every week*, page 19

Hydraulic hoses, see 1.12 *Inspection every 50 hours of operation or every week*, page 19

Wheel nuts, see 1.12 *Inspection every 50 hours of operation or every week*, page 19

Crane axles and interlocks, see 1.12 *Inspection every 50 hours of operation or every week*, page 19

Telescopic extension chains, see 1.12 *Inspection every 50 hours of operation or every week*, page 19

Oil level, winch gearbox, see 1.12 *Inspection every 50 hours of operation or every week*, page 19

## 2.23 Report, service during the warranty period after 1,500 hours of operation (cont'd.) Copy Customer's Copies

| Check                    |  |
|--------------------------|--|
| <input type="checkbox"/> | Oil level, hub reductions  |
| <input type="checkbox"/> | Oil level, differential  |
| <input type="checkbox"/> | Oil level, gearbox   |
| <input type="checkbox"/> | Oil level, bogie cases   |
| <input type="checkbox"/> | Oil level, winch gearbox   |
| <input type="checkbox"/> | Fan heating element  |
| <input type="checkbox"/> | Cooling hoses (cracks, hose clamps, etc.)                                    |
| <input type="checkbox"/> | Coolant, frost protection  |
| <input type="checkbox"/> | Air filter dust collector  |
| <input type="checkbox"/> | Air compressor   |
| <input type="checkbox"/> | Battery, fluid level, poles and connections                                  |
| <input type="checkbox"/> | Re-tightening of the upper and lower expander bolts in the articulated joint |
| <input type="checkbox"/> | Pressure setting for crane   |
| <input type="checkbox"/> | Brake function, traffic brake  |
| <input type="checkbox"/> | Brake function, working brake  |
| <input type="checkbox"/> | Brake function, parking brake  |
| <input type="checkbox"/> | Inspection of forestry crane   |
| <input type="checkbox"/> | Check function of air conditioning system.                                   |
| <input type="checkbox"/> | Sign-off for Warranty Service 1,000 h in GreControl                          |

---

### Service information

Service performed date \_\_\_\_\_

Service performed by:

\_\_\_\_\_  
*Machine owner/Authorised service dealer*

### The report must be submitted to

Gremo AB, FAO: SERVICE

Box 44

311 51 ÄTRAN

## 2.24 Fault report 1,500 h Copy Customer's Copies

**Machine information**

Machine number: \_\_\_\_\_

**Machine owner**

Electrical system:

---

---

---

---

Hydraulics:

---

---

---

---

---

Hoses:

---

---

---

---

Tyres:

---

---

---

---

Chassis:

---

---

---

---

Miscellaneous:

---

---

---

## 2.25 Report, service during the warranty period after 2,000 hours of operation

**Machine information**

Machine number: \_\_\_\_\_

**Machine owner**

**Telephone number**

Machine: \_\_\_\_\_

Operator: \_\_\_\_\_

**Replacement**

Engine oil and oil filter

Fuel filter

Fuel prefilter

Air filter (only in the event of an alarm being triggered)

Air filter safety insert (only in the event of an alarm being triggered)

Coolant in cooling system (at least every second year)

Gearbox oil

Oil in the differential housing

Oil in hub reductions

Oil in bogie housings

Hydraulic oil (for negative oil test)

Crankcase ventilation filter

Return oil filter for working hydraulics

Return oil filter for hydrostat

Breather filter hydraulic oil tank

Hydrostatic pump filter

Off-line filter

Pilot filter for crane valve

Oil in the crane base

Winch's gearbox oil

**Replacement**

Air conditioning system's fresh air filter

Air conditioning system, recirculation filter

**Lubricated**

All lubrication points

**Cleaned**

Vibration damper, brake lining

Radiator

Air conditioning system's condensor

Rotator's magnet plugs (if fitted)

**Sampling**

Oil sample working hydraulics

## 2.26 Report, service during the warranty period after 2,000 hours of operation (cont'd.)

**Checked**

Crankcase ventilation, diesel engine, (see Daily checks)

Air inlet hoses, diesel engine, (see Daily checks)

Hydraulic oil level (see Daily checks)

Leakage, fluid sub-systems, (see Daily checks)

Fire extinguishing (See Daily checks + Inspection every 50 hours of operation)

Grapple (see Daily checks)

Tyres, pressure and condition (see Daily checks + Inspection every 50 hours of operation)

Engine's drive belt (See Inspection every 50 hours of operation)

Hydraulic hoses (See Inspection every 50 hours of operation)

Wheel bolts (See Inspection every 50 hours of operation)

Crane axles and interlocks (See Inspection every 50 hours of operation)

Boom extension chains (See Inspection every 50 hours of operation)

**Checked**

Machine cleanliness

Belt tensioner

Exhaust system

Radiator fan

Cooling hoses (cracks, hose clamps, etc.)

Coolant, antifreeze

Air filter dust collector

Batteries, connections and installation

Re-tightening of the upper and lower expander bolts in the articulated joint

Pressure setting for crane

Brake function, traffic brake

Brake function, working brake

Brake function, parking brake

Inspection as in Inspection Journal for forestry crane

Air conditioning function control

Play in articulated steering joint

Wear plate bogie housings

Tightening the screw joints

Sign-off for Warranty Service 2,000 h in GreControl

**Service information**

Service performed date: \_\_\_\_\_

Service performed by: \_\_\_\_\_

*Authorised service dealer*

---

Service approved:

\_\_\_\_\_

*Customer signature*

**The report must be submitted to:**

GreMO AB, Att Service

Box 44

311 51 ÄTRAN

## 2.27 Fault report 2,000 h

|  |
|--|
| <p><b>Machine information</b></p> <p>Machine number: _____</p> <p><b>Machine owner</b></p> |
|--|

Electrical system:

---

---

---

---

Hydraulics:

---

---

---

---

---

Hoses:

---

---

---

---

Tyres:

---

---

---

---

Chassis:

---

---

---

---

Miscellaneous:

---

---

---

## 2.28 Report, service during the warranty period after 2,000 hours of operation Copy Customer's Copies

### Machine information

Machine number: \_\_\_\_\_

### Machine owner

### Telephone number

Machine: \_\_\_\_\_

Operator: \_\_\_\_\_

### Replacement

- Engine oil and oil filter
- Fuel filter
- Fuel prefilter
- Air filter (only in the event of an alarm being triggered)
- Air filter safety insert (only in the event of an alarm being triggered)
- Coolant in cooling system (at least every second year)
- Gearbox oil
- Oil in the differential housing
- Oil in hub reductions
- Oil in bogie housings
- Hydraulic oil (for negative oil test)
- Crankcase ventilation filter
- Return oil filter for working hydraulics
- Return oil filter for hydrostat
- Breather filter hydraulic oil tank
- Hydrostatic pump filter
- Off-line filter
- Pilot filter for crane valve
- Oil in the crane base
- Winch's gearbox oil

### Replacement

- Air conditioning system's fresh air filter
- Air conditioning system, recirculation filter

### Lubricated

- All lubrication points

### Cleaned

- Vibration damper, brake lining
- Radiator
- Air conditioning system's condensor
- Rotator's magnet plugs (if fitted)

### Sampling

- Oil sample working hydraulics

## 2.29 Report, service during the warranty period after 2,000 hours of operation (cont'd.) Copy Customer's Copies

| <b>Checked</b>           |   |
|--------------------------|---|
| <input type="checkbox"/> | Crankcase ventilation, diesel engine, (see Daily checks)                                  |
| <input type="checkbox"/> | Air inlet hoses, diesel engine, (see Daily checks)  |
| <input type="checkbox"/> | Hydraulic oil level (see Daily checks)  |
| <input type="checkbox"/> | Leakage, fluid sub-systems, (see Daily checks)  |
| <input type="checkbox"/> | Fire extinguishing (See Daily checks + Inspection every 50 hours of operation)            |
| <input type="checkbox"/> | Grapple (see Daily checks)  |
| <input type="checkbox"/> | Tyres, pressure and condition (see Daily checks + Inspection every 50 hours of operation) |
| <input type="checkbox"/> | Engine's drive belt (See Inspection every 50 hours of operation)                          |
| <input type="checkbox"/> | Hydraulic hoses (See Inspection every 50 hours of operation)                              |
| <input type="checkbox"/> | Wheel bolts (See Inspection every 50 hours of operation)                                  |
| <input type="checkbox"/> | Crane axles and interlocks (See Inspection every 50 hours of operation)                   |
| <input type="checkbox"/> | Boom extension chains (See Inspection every 50 hours of operation)                        |

| <b>Checked</b>           |  |
|--------------------------|--|
| <input type="checkbox"/> | Machine cleanliness  |
| <input type="checkbox"/> |  |
| <input type="checkbox"/> | Belt tensioner   |
| <input type="checkbox"/> | Exhaust system   |
| <input type="checkbox"/> | Radiator fan   |
| <input type="checkbox"/> | Cooling hoses (cracks, hose clamps, etc.)                                    |
| <input type="checkbox"/> | Coolant, antifreeze  |
| <input type="checkbox"/> | Air filter dust collector  |
| <input type="checkbox"/> |  |
| <input type="checkbox"/> | Batteries, connections and installation                                      |
| <input type="checkbox"/> | Re-tightening of the upper and lower expander bolts in the articulated joint |
| <input type="checkbox"/> | Pressure setting for crane   |
| <input type="checkbox"/> | Brake function, traffic brake  |
| <input type="checkbox"/> | Brake function, working brake  |
| <input type="checkbox"/> | Brake function, parking brake  |
| <input type="checkbox"/> | Inspection as in Inspection Journal for forestry crane                       |
| <input type="checkbox"/> | Air conditioning function control  |
| <input type="checkbox"/> | Play in articulated steering joint   |
| <input type="checkbox"/> | Wear plate bogie housings  |
| <input type="checkbox"/> | Tightening the screw joints  |
| <input type="checkbox"/> | Sign-off for Warranty Service 2,000 h in GreControl                          |

| <b>Service information</b>       |
|----------------------------------|
| Service performed date: _____    |
| Service performed by: _____      |
| <i>Authorised service dealer</i> |
| Service approved:                |
| <br><br>                         |
| <i>Customer signature</i>        |

|   |
|---|
| <b>The report must be submitted to:</b> |
| Gremo AB, Att Service                   |
| Box 44                                  |
| 311 51 ÄTRAN                            |



## 2.30 Fault report 2,000 h Copy Customer's Copies

**Machine information**

Machine number: \_\_\_\_\_

**Machine owner**

Electrical system:

---

---

---

---

Hydraulics:

---

---

---

---

---

Hoses:

---

---

---

---

Tyres:

---

---

---

---

Chassis:

---

---

---

---

Miscellaneous:

---

---

---

## 2.31 Report, service during the warranty period after 2,500 hours of operation

### Machine information

Machine number: \_\_\_\_\_

### Machine owner

### Telephone number

Machine: \_\_\_\_\_

Operator: \_\_\_\_\_

### Replacement

- Engine oil and filter
- Fuel filter
- Fuel prefilter
- Air filter (only in the event of an alarm being triggered)
- Air filter safety insert (only in the event of an alarm being triggered)
- Fresh air filter, air conditioning unit
- Recirculation filter, air conditioning unit

### Lubrication

- All lubrication points

### Cleaning

- Clean the machine, see 1.11 *Daily maintenance (every 8-10 operating hours)*, page 16.
- Vibration damper, brake lining
- Heating element
- Condensor, air conditioning unit

### Check

- Crankcase ventilation, diesel engine, see 1.11 *Daily maintenance (every 8-10 operating hours)*, page 16
- Air inlet hoses, diesel engine, see 1.11 *Daily maintenance (every 8-10 operating hours)*, page 16
- Hydraulic oil level, see 1.11 *Daily maintenance (every 8-10 operating hours)*, page 16
- Leakage, general, see 1.11 *Daily maintenance (every 8-10 operating hours)*, page 16
- Fire extinguishing, see 1.11 *Daily maintenance (every 8-10 operating hours)*, page 16 and 1.12 *Inspection every 50 hours of operation or every week*, page 19
- Grapple, see 1.11 *Daily maintenance (every 8-10 operating hours)*, page 16
- Tyres, pressure and condition, see 1.11 *Daily maintenance (every 8-10 operating hours)*, page 16 and 1.12 *Inspection every 50 hours of operation or every week*, page 19
- Drive belt, engine, see 1.12 *Inspection every 50 hours of operation or every week*, page 19
- Hydraulic hoses, see 1.12 *Inspection every 50 hours of operation or every week*, page 19
- Wheel nuts, see 1.12 *Inspection every 50 hours of operation or every week*, page 19
- Crane axles and interlocks, see 1.12 *Inspection every 50 hours of operation or every week*, page 19
- Telescopic extension chains, see 1.12 *Inspection every 50 hours of operation or every week*, page 19
- Oil level, winch gearbox, see 1.12 *Inspection every 50 hours of operation or every week*, page 19

## 2.32 Report, service during the warranty period after 2,500 hours of operation (cont'd.)

### Check

- Oil level, hub reductions
- Oil level, differential
- Oil level, gearbox
- Oil level, bogie cases
- Oil level, winch gearbox
- Fan heating element
- Cooling hoses (cracks, hose clamps, etc.)
- Coolant, frost protection
- Air filter dust collector
- Air compressor
- Battery, fluid level, poles and connections
- Re-tightening of the upper and lower expander bolts in the articulated joint
- Pressure setting for crane
- Brake function, traffic brake
- Brake function, working brake
- Brake function, parking brake
- Inspection of forestry crane
- Check function of air conditioning system.
- Sign-off for Warranty Service 1,000 h in GreControl

---

### Service information

Service performed date \_\_\_\_\_

Service performed by:

\_\_\_\_\_

*Machine owner/Authorised service dealer*

### The report must be submitted to

Greco AB, FAO: SERVICE

Box 44

311 51 ÄTRAN

## 2.33 Fault report 2,500 h

|  |
|--|
| <p><b>Machine information</b></p> <p>Machine number: _____</p> <p><b>Machine owner</b></p> |
|--|

Electrical system:

---

---

---

---

Hydraulics:

---

---

---

---

---

Hoses:

---

---

---

---

Tyres:

---

---

---

---

Chassis:

---

---

---

---

Miscellaneous:

---

---

---

## 2.34 Report, service during the warranty period after 2,500 hours of operation Copy Customer's Copy

**Machine information**

Machine number: \_\_\_\_\_

**Machine owner**

**Telephone number**

Machine: \_\_\_\_\_

Operator: \_\_\_\_\_

**Replacement**

Engine oil and filter

Fuel filter

Fuel prefilter

Air filter (only in the event of an alarm being triggered)

Air filter safety insert (only in the event of an alarm being triggered)

Fresh air filter, air conditioning unit

Recirculation filter, air conditioning unit

**Lubrication**

All lubrication points

**Cleaning**

Clean the machine, see 1.11 *Daily maintenance (every 8-10 operating hours)*, page 16.

Vibration damper, brake lining

Heating element

Condensor, air conditioning unit

**Check**

Crankcase ventilation, diesel engine, see 1.11 *Daily maintenance (every 8-10 operating hours)*, page 16

Air inlet hoses, diesel engine, see 1.11 *Daily maintenance (every 8-10 operating hours)*, page 16

Hydraulic oil level, see 1.11 *Daily maintenance (every 8-10 operating hours)*, page 16

Leakage, general, see 1.11 *Daily maintenance (every 8-10 operating hours)*, page 16

Fire extinguishing, see 1.11 *Daily maintenance (every 8-10 operating hours)*, page 16 and 1.12 *Inspection every 50 hours of operation or every week*, page 19

Grapple, see 1.11 *Daily maintenance (every 8-10 operating hours)*, page 16

Tyres, pressure and condition, see 1.11 *Daily maintenance (every 8-10 operating hours)*, page 16 and 1.12 *Inspection every 50 hours of operation or every week*, page 19

Drive belt, engine, see 1.12 *Inspection every 50 hours of operation or every week*, page 19

Hydraulic hoses, see 1.12 *Inspection every 50 hours of operation or every week*, page 19

Wheel nuts, see 1.12 *Inspection every 50 hours of operation or every week*, page 19

Crane axles and interlocks, see 1.12 *Inspection every 50 hours of operation or every week*, page 19

Telescopic extension chains, see 1.12 *Inspection every 50 hours of operation or every week*, page 19

Oil level, winch gearbox, see 1.12 *Inspection every 50 hours of operation or every week*, page 19

## 2.35 Report, service during the warranty period after 2,500 hours of operation (cont'd.) Copy Customer's Copy

| Check                    |  |
|--------------------------|--|
| <input type="checkbox"/> | Oil level, hub reductions  |
| <input type="checkbox"/> | Oil level, differential  |
| <input type="checkbox"/> | Oil level, gearbox   |
| <input type="checkbox"/> | Oil level, bogie cases   |
| <input type="checkbox"/> | Oil level, winch gearbox   |
| <input type="checkbox"/> | Fan heating element  |
| <input type="checkbox"/> | Cooling hoses (cracks, hose clamps, etc.)                                    |
| <input type="checkbox"/> | Coolant, frost protection  |
| <input type="checkbox"/> | Air filter dust collector  |
| <input type="checkbox"/> | Air compressor   |
| <input type="checkbox"/> | Battery, fluid level, poles and connections                                  |
| <input type="checkbox"/> | Re-tightening of the upper and lower expander bolts in the articulated joint |
| <input type="checkbox"/> | Pressure setting for crane   |
| <input type="checkbox"/> | Brake function, traffic brake  |
| <input type="checkbox"/> | Brake function, working brake  |
| <input type="checkbox"/> | Brake function, parking brake  |
| <input type="checkbox"/> | Inspection of forestry crane   |
| <input type="checkbox"/> | Check function of air conditioning system.                                   |
| <input type="checkbox"/> | Sign-off for Warranty Service 1,000 h in GreControl                          |

---

### Service information

Service performed date \_\_\_\_\_

Service performed by:

\_\_\_\_\_  
*Machine owner/Authorised service dealer*

### The report must be submitted to

Gremo AB, FAO: SERVICE

Box 44

311 51 ÄTRAN

## 2.36 Fault report 2,500 h Copy Customer's Copy

|  |
|--|
| <p><b>Machine information</b></p> <p>Machine number: _____</p> <p><b>Machine owner</b></p> |
|--|

Electrical system:

---

---

---

---

Hydraulics:

---

---

---

---

---

Hoses:

---

---

---

---

Tyres:

---

---

---

---

Chassis:

---

---

---

---

Miscellaneous:

---

---

---

## 2.37 Report, service during the warranty period after 3,000 hours of operation

**Machine information**

Machine number: \_\_\_\_\_

**Machine owner**

**Telephone number**

Machine: \_\_\_\_\_

Operator: \_\_\_\_\_

**Replacement**

Engine oil and oil filter

Fuel filter

Fuel prefilter

Air filter (only in the event of an alarm being triggered)

Air filter safety insert (only in the event of an alarm being triggered)

Coolant in cooling system (at least every second year)

Gearbox oil

Oil in the differential housing

Oil in hub reductions

Oil in bogie housings

Hydraulic oil (for negative oil test)

Crankcase ventilation filter

Return oil filter for working hydraulics

Return oil filter for hydrostat

Breather filter hydraulic oil tank

Hydrostatic pump filter

Off-line filter

Pilot filter for crane valve

Oil in the crane base

Winch's gearbox oil

**Replacement**

Air conditioning system's fresh air filter

Air conditioning system, recirculation filter

**Lubricated**

All lubrication points

**Cleaned**

Vibration damper, brake lining

Radiator

Air conditioning system's condensor

Rotator's magnet plugs (if fitted)

**Sampling**

Oil sample working hydraulics



## 2.38 Report, service during the warranty period after 3,000 hours of operation (cont'd.)

| <b>Checked</b>           |   |
|--------------------------|---|
| <input type="checkbox"/> | Crankcase ventilation, diesel engine, (see Daily checks)                                  |
| <input type="checkbox"/> | Air inlet hoses, diesel engine, (see Daily checks)  |
| <input type="checkbox"/> | Hydraulic oil level (see Daily checks)  |
| <input type="checkbox"/> | Leakage, fluid sub-systems, (see Daily checks)  |
| <input type="checkbox"/> | Fire extinguishing (See Daily checks + Inspection every 50 hours of operation)            |
| <input type="checkbox"/> | Grapple (see Daily checks)  |
| <input type="checkbox"/> | Tyres, pressure and condition (see Daily checks + Inspection every 50 hours of operation) |
| <input type="checkbox"/> | Engine's drive belt (See Inspection every 50 hours of operation)                          |
| <input type="checkbox"/> | Hydraulic hoses (See Inspection every 50 hours of operation)                              |
| <input type="checkbox"/> | Wheel bolts (See Inspection every 50 hours of operation)                                  |
| <input type="checkbox"/> | Crane axles and interlocks (See Inspection every 50 hours of operation)                   |
| <input type="checkbox"/> | Boom extension chains (See Inspection every 50 hours of operation)                        |

| <b>Checked</b>           |  |
|--------------------------|--|
| <input type="checkbox"/> | Machine cleanliness  |
| <input type="checkbox"/> |  |
| <input type="checkbox"/> | Belt tensioner   |
| <input type="checkbox"/> | Exhaust system   |
| <input type="checkbox"/> | Radiator fan   |
| <input type="checkbox"/> | Cooling hoses (cracks, hose clamps, etc.)                                    |
| <input type="checkbox"/> | Coolant, antifreeze  |
| <input type="checkbox"/> | Air filter dust collector  |
| <input type="checkbox"/> |  |
| <input type="checkbox"/> | Batteries, connections and installation                                      |
| <input type="checkbox"/> | Re-tightening of the upper and lower expander bolts in the articulated joint |
| <input type="checkbox"/> | Pressure setting for crane   |
| <input type="checkbox"/> | Brake function, traffic brake  |
| <input type="checkbox"/> | Brake function, working brake  |
| <input type="checkbox"/> | Brake function, parking brake  |
| <input type="checkbox"/> | Inspection as in Inspection Journal for forestry crane                       |
| <input type="checkbox"/> | Air conditioning function control  |
| <input type="checkbox"/> | Play in articulated steering joint   |
| <input type="checkbox"/> | Wear plate bogie housings  |
| <input type="checkbox"/> | Tightening the screw joints  |
| <input type="checkbox"/> | Sign-off for Warranty Service 2,000 h in GreControl                          |

| <b>Service information</b>       |
|----------------------------------|
| Service performed date: _____    |
| Service performed by: _____      |
| <i>Authorised service dealer</i> |
| Service approved:                |
|                                  |
| <i>Customer signature</i>        |

|   |
|---|
| <b>The report must be submitted to:</b> |
| Gremo AB, Att Service                   |
| Box 44                                  |
| 311 51 ÄTRAN                            |

## 2.39 Fault report 3,000 h

|  |
|--|
| <p><b>Machine information</b></p> <p>Machine number: _____</p> <p><b>Machine owner</b></p> |
|--|

Electrical system:

---

---

---

---

Hydraulics:

---

---

---

---

---

Hoses:

---

---

---

---

Tyres:

---

---

---

---

Chassis:

---

---

---

---

Miscellaneous:

---

---

---

## 2.40 Report, service during the warranty period after 3,000 hours of operation Copy Customer's Copy

### Machine information

Machine number: \_\_\_\_\_

### Machine owner

### Telephone number

Machine: \_\_\_\_\_

Operator: \_\_\_\_\_

### Replacement

- Engine oil and oil filter
- Fuel filter
- Fuel prefilter
- Air filter (only in the event of an alarm being triggered)
- Air filter safety insert (only in the event of an alarm being triggered)
- Coolant in cooling system (at least every second year)
- Gearbox oil
- Oil in the differential housing
- Oil in hub reductions
- Oil in bogie housings
- Hydraulic oil (for negative oil test)
- Crankcase ventilation filter
- Return oil filter for working hydraulics
- Return oil filter for hydrostat
- Breather filter hydraulic oil tank
- Hydrostatic pump filter
- Off-line filter
- Pilot filter for crane valve
- Oil in the crane base
- Winch's gearbox oil

### Replacement

- Air conditioning system's fresh air filter
- Air conditioning system, recirculation filter

### Lubricated

- All lubrication points

### Cleaned

- Vibration damper, brake lining
- Radiator
- Air conditioning system's condensor
- Rotator's magnet plugs (if fitted)

### Sampling

- Oil sample working hydraulics

## 2.41 Report, service during the warranty period after 3,000 hours of operation (cont'd.) Copy Customer's Copy

| <b>Checked</b>           |   |
|--------------------------|---|
| <input type="checkbox"/> | Crankcase ventilation, diesel engine, (see Daily checks)                                  |
| <input type="checkbox"/> | Air inlet hoses, diesel engine, (see Daily checks)  |
| <input type="checkbox"/> | Hydraulic oil level (see Daily checks)  |
| <input type="checkbox"/> | Leakage, fluid sub-systems, (see Daily checks)  |
| <input type="checkbox"/> | Fire extinguishing (See Daily checks + Inspection every 50 hours of operation)            |
| <input type="checkbox"/> | Grapple (see Daily checks)  |
| <input type="checkbox"/> | Tyres, pressure and condition (see Daily checks + Inspection every 50 hours of operation) |
| <input type="checkbox"/> | Engine's drive belt (See Inspection every 50 hours of operation)                          |
| <input type="checkbox"/> | Hydraulic hoses (See Inspection every 50 hours of operation)                              |
| <input type="checkbox"/> | Wheel bolts (See Inspection every 50 hours of operation)                                  |
| <input type="checkbox"/> | Crane axles and interlocks (See Inspection every 50 hours of operation)                   |
| <input type="checkbox"/> | Boom extension chains (See Inspection every 50 hours of operation)                        |

| <b>Checked</b>           |  |
|--------------------------|--|
| <input type="checkbox"/> | Machine cleanliness  |
| <input type="checkbox"/> |  |
| <input type="checkbox"/> | Belt tensioner   |
| <input type="checkbox"/> | Exhaust system   |
| <input type="checkbox"/> | Radiator fan   |
| <input type="checkbox"/> | Cooling hoses (cracks, hose clamps, etc.)                                    |
| <input type="checkbox"/> | Coolant, antifreeze  |
| <input type="checkbox"/> | Air filter dust collector  |
| <input type="checkbox"/> |  |
| <input type="checkbox"/> | Batteries, connections and installation                                      |
| <input type="checkbox"/> | Re-tightening of the upper and lower expander bolts in the articulated joint |
| <input type="checkbox"/> | Pressure setting for crane   |
| <input type="checkbox"/> |  |
| <input type="checkbox"/> | Brake function, traffic brake  |
| <input type="checkbox"/> |  |
| <input type="checkbox"/> | Brake function, working brake  |
| <input type="checkbox"/> |  |
| <input type="checkbox"/> | Brake function, parking brake  |
| <input type="checkbox"/> |  |
| <input type="checkbox"/> | Inspection as in Inspection Journal for forestry crane                       |
| <input type="checkbox"/> |  |
| <input type="checkbox"/> | Air conditioning function control  |
| <input type="checkbox"/> |  |
| <input type="checkbox"/> | Play in articulated steering joint   |
| <input type="checkbox"/> |  |
| <input type="checkbox"/> | Wear plate bogie housings  |
| <input type="checkbox"/> |  |
| <input type="checkbox"/> | Tightening the screw joints  |
| <input type="checkbox"/> |  |
| <input type="checkbox"/> | Sign-off for Warranty Service 2,000 h in GreControl                          |

| <b>Service information</b>       |
|----------------------------------|
| Service performed date: _____    |
| Service performed by: _____      |
| <i>Authorised service dealer</i> |
| Service approved:                |
|                                  |
| <i>Customer signature</i>        |

|   |
|---|
| <b>The report must be submitted to:</b> |
| Gremo AB, Att Service                   |
| Box 44                                  |
| 311 51 ÄTRAN                            |

## 2.42 Fault report 3,000 h Copy Customer's Copy

|  |
|--|
| <p><b>Machine information</b></p> <p>Machine number: _____</p> <p><b>Machine owner</b></p> |
|--|

Electrical system:

---

---

---

---

Hydraulics:

---

---

---

---

---

Hoses:

---

---

---

---

Tyres:

---

---

---

---

Chassis:

---

---

---

---

Miscellaneous:

---

---

---

## 2.43 Report, service during the warranty period after 3,500 hours of operation

### Machine information

Machine number: \_\_\_\_\_

### Machine owner

### Telephone number

Machine: \_\_\_\_\_

Operator: \_\_\_\_\_

### Replacement

- Engine oil and filter
- Fuel filter
- Fuel prefilter
- Air filter (only in the event of an alarm being triggered)
- Air filter safety insert (only in the event of an alarm being triggered)
- Fresh air filter, air conditioning unit
- Recirculation filter, air conditioning unit

### Lubrication

- All lubrication points

### Cleaning

- Clean the machine, see 1.11 *Daily maintenance (every 8-10 operating hours)*, page 16.
- Vibration damper, brake lining
- Heating element
- Condensor, air conditioning unit

### Check

- Crankcase ventilation, diesel engine, see 1.11 *Daily maintenance (every 8-10 operating hours)*, page 16
- Air inlet hoses, diesel engine, see 1.11 *Daily maintenance (every 8-10 operating hours)*, page 16
- Hydraulic oil level, see 1.11 *Daily maintenance (every 8-10 operating hours)*, page 16
- Leakage, general, see 1.11 *Daily maintenance (every 8-10 operating hours)*, page 16
- Fire extinguishing, see 1.11 *Daily maintenance (every 8-10 operating hours)*, page 16 and 1.12 *Inspection every 50 hours of operation or every week*, page 19
- Grapple, see 1.11 *Daily maintenance (every 8-10 operating hours)*, page 16
- Tyres, pressure and condition, see 1.11 *Daily maintenance (every 8-10 operating hours)*, page 16 and 1.12 *Inspection every 50 hours of operation or every week*, page 19
- Drive belt, engine, see 1.12 *Inspection every 50 hours of operation or every week*, page 19
- Hydraulic hoses, see 1.12 *Inspection every 50 hours of operation or every week*, page 19
- Wheel nuts, see 1.12 *Inspection every 50 hours of operation or every week*, page 19
- Crane axles and interlocks, see 1.12 *Inspection every 50 hours of operation or every week*, page 19
- Telescopic extension chains, see 1.12 *Inspection every 50 hours of operation or every week*, page 19
- Oil level, winch gearbox, see 1.12 *Inspection every 50 hours of operation or every week*, page 19

## 2.44 Report, service during the warranty period after 3,500 hours of operation (cont'd.)

### Check

- Oil level, hub reductions
- Oil level, differential
- Oil level, gearbox
- Oil level, bogie cases
- Oil level, winch gearbox
- Fan heating element
- Cooling hoses (cracks, hose clamps, etc.)
- Coolant, frost protection
- Air filter dust collector
- Air compressor
- Battery, fluid level, poles and connections
- Re-tightening of the upper and lower expander bolts in the articulated joint
- Pressure setting for crane
- Brake function, traffic brake
- Brake function, working brake
- Brake function, parking brake
- Inspection of forestry crane
- Check function of air conditioning system.
- Sign-off for Warranty Service 1,000 h in GreControl

---

### Service information

Service performed date \_\_\_\_\_

Service performed by:  
\_\_\_\_\_

*Machine owner/Authorised service dealer*

### The report must be submitted to

Greco AB, FAO: SERVICE

Box 44

311 51 ÄTRAN

## 2.45 Fault report 3,500 h

|  |
|--|
| <p><b>Machine information</b></p> <p>Machine number: _____</p> <p><b>Machine owner</b></p> |
|--|

Electrical system:

---

---

---

---

Hydraulics:

---

---

---

---

---

---

Hoses:

---

---

---

---

Tyres:

---

---

---

---

Chassis:

---

---

---

---

Miscellaneous:

---

---

---



## 2.46 Report, service during the warranty period after 3,500 hours of operation Copy Customer's Copy

|  |
|--|
| <p><b>Machine information</b></p> <p>Machine number: _____</p> <p><b>Machine owner</b></p> |
|--|

|   |
|---|
| <p><b>Telephone number</b></p> <p>Machine: _____</p> <p>Operator: _____</p> |
|---|

|  |
|--|
| <p><b>Replacement</b></p> <p><input type="checkbox"/> Engine oil and filter</p> <p><input type="checkbox"/> Fuel filter</p> <p><input type="checkbox"/> Fuel prefilter</p> <p><input type="checkbox"/> Air filter (only in the event of an alarm being triggered)</p> <p><input type="checkbox"/> Air filter safety insert (only in the event of an alarm being triggered)</p> <p><input type="checkbox"/> Fresh air filter, air conditioning unit</p> <p><input type="checkbox"/> Recirculation filter, air conditioning unit</p> |
|--|

|  |
|--|
| <p><b>Lubrication</b></p> <p><input type="checkbox"/> All lubrication points</p> |
|--|

|  |
|--|
| <p><b>Cleaning</b></p> <p><input type="checkbox"/> Clean the machine, see 1.11 <i>Daily maintenance (every 8-10 operating hours)</i>, page 16.</p> <p><input type="checkbox"/> Vibration damper, brake lining</p> <p><input type="checkbox"/> Heating element</p> <p><input type="checkbox"/> Condensor, air conditioning unit</p> |
|--|

|  |
|--|
| <p><b>Check</b></p> <p><input type="checkbox"/> Crankcase ventilation, diesel engine, see 1.11 <i>Daily maintenance (every 8-10 operating hours)</i>, page 16</p> <p><input type="checkbox"/> Air inlet hoses, diesel engine, see 1.11 <i>Daily maintenance (every 8-10 operating hours)</i>, page 16</p> <p><input type="checkbox"/> Hydraulic oil level, see 1.11 <i>Daily maintenance (every 8-10 operating hours)</i>, page 16</p> <p><input type="checkbox"/> Leakage, general, see 1.11 <i>Daily maintenance (every 8-10 operating hours)</i>, page 16</p> <p><input type="checkbox"/> Fire extinguishing, see 1.11 <i>Daily maintenance (every 8-10 operating hours)</i>, page 16 and 1.12 <i>Inspection every 50 hours of operation or every week</i>, page 19</p> <p><input type="checkbox"/> Grapple, see 1.11 <i>Daily maintenance (every 8-10 operating hours)</i>, page 16</p> <p><input type="checkbox"/> Tyres, pressure and condition, see 1.11 <i>Daily maintenance (every 8-10 operating hours)</i>, page 16 and 1.12 <i>Inspection every 50 hours of operation or every week</i>, page 19</p> <p><input type="checkbox"/> Drive belt, engine, see 1.12 <i>Inspection every 50 hours of operation or every week</i>, page 19</p> <p><input type="checkbox"/> Hydraulic hoses, see 1.12 <i>Inspection every 50 hours of operation or every week</i>, page 19</p> <p><input type="checkbox"/> Wheel nuts, see 1.12 <i>Inspection every 50 hours of operation or every week</i>, page 19</p> <p><input type="checkbox"/> Crane axles and interlocks, see 1.12 <i>Inspection every 50 hours of operation or every week</i>, page 19</p> <p><input type="checkbox"/> Telescopic extension chains, see 1.12 <i>Inspection every 50 hours of operation or every week</i>, page 19</p> <p><input type="checkbox"/> Oil level, winch gearbox, see 1.12 <i>Inspection every 50 hours of operation or every week</i>, page 19</p> |
|--|

## 2.47 Report, service during the warranty period after 3,500 hours of operation (cont'd.) Copy Customer's Copy

| Check                    |  |
|--------------------------|--|
| <input type="checkbox"/> | Oil level, hub reductions  |
| <input type="checkbox"/> | Oil level, differential  |
| <input type="checkbox"/> | Oil level, gearbox   |
| <input type="checkbox"/> | Oil level, bogie cases   |
| <input type="checkbox"/> | Oil level, winch gearbox   |
| <input type="checkbox"/> | Fan heating element  |
| <input type="checkbox"/> | Cooling hoses (cracks, hose clamps, etc.)                                    |
| <input type="checkbox"/> | Coolant, frost protection  |
| <input type="checkbox"/> | Air filter dust collector  |
| <input type="checkbox"/> | Air compressor   |
| <input type="checkbox"/> | Battery, fluid level, poles and connections                                  |
| <input type="checkbox"/> | Re-tightening of the upper and lower expander bolts in the articulated joint |
| <input type="checkbox"/> | Pressure setting for crane   |
| <input type="checkbox"/> | Brake function, traffic brake  |
| <input type="checkbox"/> | Brake function, working brake  |
| <input type="checkbox"/> | Brake function, parking brake  |
| <input type="checkbox"/> | Inspection of forestry crane   |
| <input type="checkbox"/> | Check function of air conditioning system.                                   |
| <input type="checkbox"/> | Sign-off for Warranty Service 1,000 h in GreControl                          |

---

### Service information

Service performed date \_\_\_\_\_

Service performed by:

\_\_\_\_\_  
*Machine owner/Authorised service dealer*

### The report must be submitted to

Gremo AB, FAO: SERVICE

Box 44

311 51 ÄTRAN

## 2.48 Fault report 3,500 h Copy Customer's Copy

|  |
|--|
| <p><b>Machine information</b></p> <p>Machine number: _____</p> <p><b>Machine owner</b></p> |
|--|

Electrical system:

---

---

---

---

Hydraulics:

---

---

---

---

---

Hoses:

---

---

---

---

Tyres:

---

---

---

---

Chassis:

---

---

---

---

Miscellaneous:

---

---

---

## 2.49 Report, service during the warranty period after 4,000 hours of operation

|   |
|---|
| <b>Machine information</b><br>Machine number: _____<br><b>Machine owner</b> |
|---|

|  |
|--|
| <b>Telephone number</b><br>Machine: _____<br>Operator: _____ |
|--|

|   |
|---|
| <b>Replacement</b>  |
| <input type="checkbox"/> Engine oil and oil filter  |
| <input type="checkbox"/> Fuel filter  |
| <input type="checkbox"/> Fuel prefilter   |
| <input type="checkbox"/> Air filter (only in the event of an alarm being triggered)               |
| <input type="checkbox"/> Air filter safety insert (only in the event of an alarm being triggered) |
| <input type="checkbox"/> Coolant in cooling system (at least every second year)                   |
| <input type="checkbox"/> Gearbox oil  |
| <input type="checkbox"/> Oil in the differential housing  |
| <input type="checkbox"/> Oil in hub reductions  |
| <input type="checkbox"/> Oil in bogie housings  |
| <input type="checkbox"/> Hydraulic oil (for negative oil test)                                    |
| <input type="checkbox"/> Crankcase ventilation filter   |
| <input type="checkbox"/> Return oil filter for working hydraulics                                 |
| <input type="checkbox"/> Return oil filter for hydrostat  |
| <input type="checkbox"/> Breather filter hydraulic oil tank                                       |
| <input type="checkbox"/> Hydrostatic pump filter  |
| <input type="checkbox"/> Off-line filter  |
| <input type="checkbox"/> Pilot filter for crane valve   |
| <input type="checkbox"/> Oil in the crane base  |
| <input type="checkbox"/> Winch's gearbox oil  |

|  |
|--|
| <b>Replacement</b>   |
| <input type="checkbox"/> Air conditioning system's fresh air filter    |
| <input type="checkbox"/> Air conditioning system, recirculation filter |

|   |
|---|
| <b>Lubricated</b>                               |
| <input type="checkbox"/> All lubrication points |

|  |
|--|
| <b>Cleaned</b>   |
| <input type="checkbox"/> Vibration damper, brake lining      |
| <input type="checkbox"/> Radiator                            |
| <input type="checkbox"/> Air conditioning system's condensor |
| <input type="checkbox"/> Rotator's magnet plugs (if fitted)  |

|  |
|--|
| <b>Sampling</b>  |
| <input type="checkbox"/> Oil sample working hydraulics |

## 2.50 Report, service during the warranty period after 4,000 hours of operation (cont'd.)

| <b>Checked</b>           |   |
|--------------------------|---|
| <input type="checkbox"/> | Crankcase ventilation, diesel engine, (see Daily checks)                                  |
| <input type="checkbox"/> | Air inlet hoses, diesel engine, (see Daily checks)  |
| <input type="checkbox"/> | Hydraulic oil level (see Daily checks)  |
| <input type="checkbox"/> | Leakage, fluid sub-systems, (see Daily checks)  |
| <input type="checkbox"/> | Fire extinguishing (See Daily checks + Inspection every 50 hours of operation)            |
| <input type="checkbox"/> | Grapple (see Daily checks)  |
| <input type="checkbox"/> | Tyres, pressure and condition (see Daily checks + Inspection every 50 hours of operation) |
| <input type="checkbox"/> | Engine's drive belt (See Inspection every 50 hours of operation)                          |
| <input type="checkbox"/> | Hydraulic hoses (See Inspection every 50 hours of operation)                              |
| <input type="checkbox"/> | Wheel bolts (See Inspection every 50 hours of operation)                                  |
| <input type="checkbox"/> | Crane axles and interlocks (See Inspection every 50 hours of operation)                   |
| <input type="checkbox"/> | Boom extension chains (See Inspection every 50 hours of operation)                        |

| <b>Checked</b>           |  |
|--------------------------|--|
| <input type="checkbox"/> | Machine cleanliness  |
| <input type="checkbox"/> |  |
| <input type="checkbox"/> | Belt tensioner   |
| <input type="checkbox"/> | Exhaust system   |
| <input type="checkbox"/> | Radiator fan   |
| <input type="checkbox"/> | Cooling hoses (cracks, hose clamps, etc.)                                    |
| <input type="checkbox"/> | Coolant, antifreeze  |
| <input type="checkbox"/> | Air filter dust collector  |
| <input type="checkbox"/> |  |
| <input type="checkbox"/> | Batteries, connections and installation                                      |
| <input type="checkbox"/> | Re-tightening of the upper and lower expander bolts in the articulated joint |
| <input type="checkbox"/> | Pressure setting for crane   |
| <input type="checkbox"/> | Brake function, traffic brake  |
| <input type="checkbox"/> | Brake function, working brake  |
| <input type="checkbox"/> | Brake function, parking brake  |
| <input type="checkbox"/> | Inspection as in Inspection Journal for forestry crane                       |
| <input type="checkbox"/> | Air conditioning function control  |
| <input type="checkbox"/> | Play in articulated steering joint   |
| <input type="checkbox"/> | Wear plate bogie housings  |
| <input type="checkbox"/> | Tightening the screw joints  |
| <input type="checkbox"/> | Sign-off for Warranty Service 2,000 h in GreControl                          |

| <b>Service information</b>       |
|----------------------------------|
| Service performed date: _____    |
| Service performed by: _____      |
| <i>Authorised service dealer</i> |
| Service approved:                |
|                                  |
| <i>Customer signature</i>        |

|   |
|---|
| <b>The report must be submitted to:</b> |
| Gremo AB, Att Service                   |
| Box 44                                  |
| 311 51 ÄTRAN                            |

## 2.51 Fault report 4,000 h

|  |
|--|
| <p><b>Machine information</b></p> <p>Machine number: _____</p> <p><b>Machine owner</b></p> |
|--|

Electrical system:

---

---

---

---

Hydraulics:

---

---

---

---

---

Hoses:

---

---

---

---

Tyres:

---

---

---

---

Chassis:

---

---

---

---

Miscellaneous:

---

---

---

## 2.52 Report, service during the warranty period after 4,000 hours of operation Copy Customer's Copy

### Machine information

Machine number: \_\_\_\_\_

### Machine owner

### Telephone number

Machine: \_\_\_\_\_

Operator: \_\_\_\_\_

### Replacement

- Engine oil and oil filter
- Fuel filter
- Fuel prefilter
- Air filter (only in the event of an alarm being triggered)
- Air filter safety insert (only in the event of an alarm being triggered)
- Coolant in cooling system (at least every second year)
- Gearbox oil
- Oil in the differential housing
- Oil in hub reductions
- Oil in bogie housings
- Hydraulic oil (for negative oil test)
- Crankcase ventilation filter
- Return oil filter for working hydraulics
- Return oil filter for hydrostat
- Breather filter hydraulic oil tank
- Hydrostatic pump filter
- Off-line filter
- Pilot filter for crane valve
- Oil in the crane base
- Winch's gearbox oil

### Replacement

- Air conditioning system's fresh air filter
- Air conditioning system, recirculation filter

### Lubricated

- All lubrication points

### Cleaned

- Vibration damper, brake lining
- Radiator
- Air conditioning system's condensor
- Rotator's magnet plugs (if fitted)

### Sampling

- Oil sample working hydraulics

## 2.53 Report, service during the warranty period after 4,000 hours of operation (cont'd.) Copy Customer's Copy

| <b>Checked</b>           |   |
|--------------------------|---|
| <input type="checkbox"/> | Crankcase ventilation, diesel engine, (see Daily checks)                                  |
| <input type="checkbox"/> | Air inlet hoses, diesel engine, (see Daily checks)  |
| <input type="checkbox"/> | Hydraulic oil level (see Daily checks)  |
| <input type="checkbox"/> | Leakage, fluid sub-systems, (see Daily checks)  |
| <input type="checkbox"/> | Fire extinguishing (See Daily checks + Inspection every 50 hours of operation)            |
| <input type="checkbox"/> | Grapple (see Daily checks)  |
| <input type="checkbox"/> | Tyres, pressure and condition (see Daily checks + Inspection every 50 hours of operation) |
| <input type="checkbox"/> | Engine's drive belt (See Inspection every 50 hours of operation)                          |
| <input type="checkbox"/> | Hydraulic hoses (See Inspection every 50 hours of operation)                              |
| <input type="checkbox"/> | Wheel bolts (See Inspection every 50 hours of operation)                                  |
| <input type="checkbox"/> | Crane axles and interlocks (See Inspection every 50 hours of operation)                   |
| <input type="checkbox"/> | Boom extension chains (See Inspection every 50 hours of operation)                        |

| <b>Checked</b>           |  |
|--------------------------|--|
| <input type="checkbox"/> | Machine cleanliness  |
| <input type="checkbox"/> |  |
| <input type="checkbox"/> | Belt tensioner   |
| <input type="checkbox"/> | Exhaust system   |
| <input type="checkbox"/> | Radiator fan   |
| <input type="checkbox"/> | Cooling hoses (cracks, hose clamps, etc.)                                    |
| <input type="checkbox"/> | Coolant, antifreeze  |
| <input type="checkbox"/> | Air filter dust collector  |
| <input type="checkbox"/> |  |
| <input type="checkbox"/> | Batteries, connections and installation                                      |
| <input type="checkbox"/> | Re-tightening of the upper and lower expander bolts in the articulated joint |
| <input type="checkbox"/> | Pressure setting for crane   |
| <input type="checkbox"/> | Brake function, traffic brake  |
| <input type="checkbox"/> | Brake function, working brake  |
| <input type="checkbox"/> | Brake function, parking brake  |
| <input type="checkbox"/> | Inspection as in Inspection Journal for forestry crane                       |
| <input type="checkbox"/> | Air conditioning function control  |
| <input type="checkbox"/> | Play in articulated steering joint   |
| <input type="checkbox"/> | Wear plate bogie housings  |
| <input type="checkbox"/> | Tightening the screw joints  |
| <input type="checkbox"/> | Sign-off for Warranty Service 2,000 h in GreControl                          |

| <b>Service information</b>       |
|----------------------------------|
| Service performed date: _____    |
| Service performed by: _____      |
| <i>Authorised service dealer</i> |
| Service approved:                |
| <br><br>                         |
| <i>Customer signature</i>        |

|   |
|---|
| <b>The report must be submitted to:</b> |
| Gremo AB, Att Service                   |
| Box 44                                  |
| 311 51 ÄTRAN                            |



## 2.54 Fault report 4,000 h Copy Customer's Copy

|  |
|--|
| <p><b>Machine information</b></p> <p>Machine number: _____</p> <p><b>Machine owner</b></p> |
|--|

Electrical system:

---

---

---

---

Hydraulics:

---

---

---

---

---

Hoses:

---

---

---

---

Tyres:

---

---

---

---

Chassis:

---

---

---

---

Miscellaneous:

---

---

---

